

Membership Roster and Product Reference Guide



Submersible Wastewater Pump Association

SWPA is "Forging the Future of the Submersible Wastewater Pump Industry."



Submersible Wastewater Pumping Systems Users And Specifiers Guide

2017

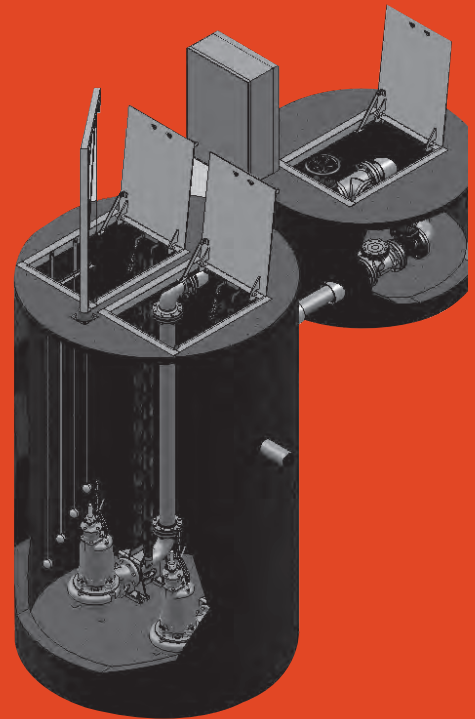

NEW for 2017

Online SWPA Training Resource Center

Your on-demand CEU & training headquarters

brought to you by

PUMPS&SYSTEMS



Courses

- The Systems Approach to Lift Station Design, Operation & Maintenance
- Grinder Pumps and Pressure Sewers
- Variable Frequency Drives
- Start-Up, Operation, Maintenance and Safety
- Pump System Optimization
- Cavitation and Air Entrainment – Advance Level Course
- Additional topics to be added: SCADA, Motors, Valves, Enclosures, Controls 101

Resources

- Industry News and Articles
- Technical Articles
- Case Studies
- SWPA Manuals, Handbooks, etc.
- Schedule of SWPA Events

- Participants may earn Continuing Education Credits (CEUs)
- ALL CONTENT FREE TO SWPA MEMBERS!**



FREE TO SWPA MEMBERS!



Training
Resource
Center

- ✓ On-Demand Webinars
- ✓ CEU Credits
- ✓ Training Manuals
- ✓ Learning Resources

One Convenient Place

Submersible Wastewater
Pump Association



Membership Roster and Product Reference Guide



Submersible Wastewater Pump Association

SWPA is "Forging the Future of the Submersible Wastewater Pump Industry."

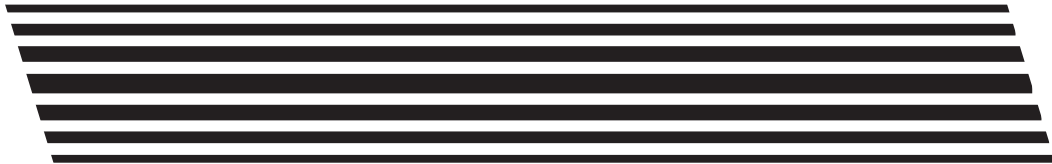

Submersible Wastewater Pumping Systems Users And Specifiers Guide 2017

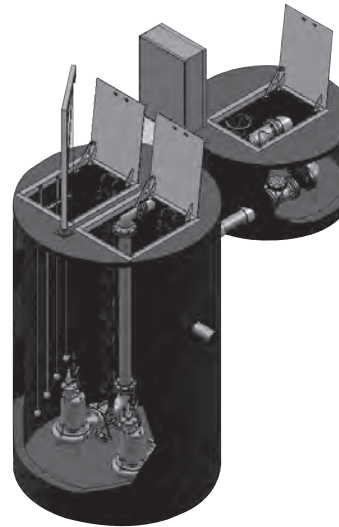

Digital copies of the 2017 Submersible Wastewater Pumping Systems
Users & Specifiers Guide are available without cost at www.swpa.org.



Submersible Wastewater Pump Association

"Forging the Future of the Submersible Wastewater Pump Industry"

Published by the Submersible Wastewater Pump Association, (SWPA) a national trade association serving the submersible wastewater pump industry, 350 North LaSalle Street, 9th Floor | Chicago, IL 60654.

Phone: 847.681.1868 | FAX: 312.475.9022 | E-Mail: swpaexdir@sbcglobal.net | Web Site: www.swpa.org

COPYRIGHT © 2017 BY THE SUBMERSIBLE WASTEWATER PUMP ASSOCIATION (SWPA)

All rights reserved. No part of this book may be reproduced, stored in a retrieval system, or transmitted in any form, or by any means, electronic, mechanical, photocopying, or otherwise, without the prior written permission of the Submersible Wastewater Pump Association.

TODAY'S ASSOCIATION TRENDS

SWPA'S STRATEGIC CONCEPTS incorporate the trends having the greatest impact on trade Associations today include a changing leadership role; value and return on investment; responsiveness; change loops (actions that result from other actions); consolidations and mergers; globalization; and image building. These trends are directly related to each other. Within that context, SWPA has created a Strategic Vision, Strategic Intent, and a Mission Statement to meet the Association's purposes and objective, as defined in its bylaws.

STRATEGIC CONCEPTS

IN THE CONDUCT of the affairs of any trade Association, there are three critical functions, which the elected leadership must address if the Association is to prosper and grow.

THE FIRST is the need to *identify* the common self-interests of the membership and the industry, thereby creating a *vision* for the Association.

THE SECOND is to develop, update and *approve* programs to serve those needs as the dynamic components of a strategic plan.

THE THIRD is to *implement* the strategic plan and monitor progress as staff and volunteer leaders carry those programs forward.

SWPA'S STRATEGIC VISION

OUR STRATEGIC VISION for SWPA is an Association that thrives by assuming a leadership role through:

- *Information* (providing access),
- *Technology* (easy dissemination of the information),
- *Membership* (people will continue to join because of a sense of community) and
- *Interaction* (Associations provide the opportunity to interact face-to-face).

SWPA'S STRATEGIC INTENT

SWPA'S STRATEGIC INTENT is to be the respected voice of the submersible wastewater pumping systems industry to influence the industry and the public.

SWPA'S MISSION STATEMENT

THE MISSION of the Submersible Wastewater Pump Association is to enhance the global wastewater environment by informing, educating and providing leadership in the design, procurement and operation of submersible wastewater pumping systems.

SWPA'S PURPOSES AND OBJECTIVES

SWPA'S PURPOSES AND OBJECTIVES are to promote increased use and consumption of Industry Products, to promote and provide for the welfare of the industry and to engage in all lawful activities appropriate for an industry trade association.

USING THIS ROSTER AND PRODUCT REFERENCE GUIDE

THIS PUBLICATION IS A SUBMERSIBLE WASTEWATER LIFT STATION USERS' AND SPECIFIERS GUIDE TO THE MEMBERS OF THE SUBMERSIBLE WASTEWATER PUMP ASSOCIATION AND THE PRODUCTS THEY MANUFACTURE AND SELL.

The *SWPA Membership Roster and Product Reference Guide* includes basic industry information as well as general information about the Association and its programs and services and member company listings by category – Pump Manufacturers, Component Manufacturers, and Associate Members. Each listing includes the company's main address, phone and fax numbers, Web Site, Product or Service Codes (see below), and sales and technical contact information.

The SWPA Membership Roster and Product Reference Guide also contains descriptive information about the Association's current and planned Technical Resources, our unique educational and training programs – all based on "The Systems Approach." – and advertising from SWPA member companies.

PRODUCT CATEGORIES AND CODES

THE FOLLOWING PRODUCT CODES ARE USED IN THIS PUBLICATION TO IDENTIFY THE TYPES OF SUBMERSIBLE PUMPS AND COMPONENT PARTS AND ACCESSORY ITEMS MANUFACTURED AND SOLD BY SWPA'S MEMBER MANUFACTURERS AND THE SERVICES PROVIDED BY THE ASSOCIATION'S ASSOCIATE MEMBERS.

SUBMERSIBLE PUMPS

<p>(AP) Axial Flow Pumps (CP) Centrifugal Pumps (DP) Dry Pit Submersibles</p>	<p>(GP) Grinder Pumps (IP) Industrial Pumps (SH) Solids Handling</p>	<p>(TP) Turbine Pumps (OP) Other Pumps, as specified</p>
---	--	--

COMPONENT PARTS AND ACCESSORIES

<p>(AC) Access Covers (AT) Alternators (BS) Basins, Fiberglass (CC) Cords/Cables (CP) Control Components (CT) Control Panels (EM) Electric Motors</p>	<p>(GR) Guide Rail Systems (LA) Lift Station Accessories (PC) Phase Converters (PM) Phase Monitors (PS) Pipe Penetration Seals (PB) Poly Basins and Accessories (SE) Seals</p>	<p>(SS) Stainless Steel Enclosures (VA) Valves (VFD) Variable Frequency Drives (WW) Wet Wells (OO) Other component parts and accessory items, as specified.</p>
---	--	---

SERVICE CATEGORIES AND CODES

THE FOLLOWING SERVICES CODES ARE USED BY SWPA TO IDENTIFY THE SERVICES RELATED TO INDUSTRY PRODUCTS PROVIDED BY SWPA'S ASSOCIATE MEMBERS.

<p>(CE) Consulting Engineering Firm (DIST) Distributor</p>	<p>(PUB) Publisher (REP) Rep Organization (SVSTA) Service Station</p>	<p>(SYSTP) System Packager (O) Other Services as Specified</p>
--	---	--

CONTENTS

Today's Association Trends	3
Strategic Concepts	3
SWPA's Strategic Vision.....	3
SWPA's Strategic Intent	3
SWPA's Mission Statement	3
SWPA's Purposes and Objectives.....	3
Using This Roster and Product Reference Guide.....	4
Product and Services Categories and Codes	4
Membership Opportunities	6
Introduction.....	7
How SWPA is <i>"Forging the Future of the Submersible Wastewater Pump Industry"</i>	8
The Submersible Wastewater Pump Story	12
Selecting Submersible Pumps.....	14
Dry Pit Submersible Pumps	15
<i>"The Systems Approach"</i>	16
Educational Training Programs	18
Standards for Submersible Pump Applications	22
Standards Setting Organizations.....	24
SWPA's Technical Resources	25
Technical Resources Under Development	29
Notes on Operation and Maintenance	30
SWPA Technical Resources Order Form	31
Pump Manufacturer Member Listings	32
<i>Pump Manufacturer Members are manufacturers of submersible wastewater pumps for municipal and industrial applications that can efficiently handle solids.</i>	
Periodic Station Checks and Inspections	34
Typical Submersible Pump Station.....	35
Component Manufacturer Member Listings	36
<i>Component Manufacturer Members are manufacturers of component parts and accessory items for submersible wastewater pumps and systems utilizing such pumps.</i>	
SWPA's Industry Community.....	38
Associate Member Listings	39
<i>Associate Members are non-manufacturers providing services related to Industry Products and/or who provide services to users of Industry Products.</i>	
Advertisers' Index.....	43
Member Company Profiles and Advertising	44

MEMBERSHIP OPPORTUNITIES

SWPA IS “FORGING THE FUTURE OF THE SUBMERSIBLE WASTEWATER PUMP INDUSTRY” WITH A WIDE ARRAY OF MEMBERSHIP BENEFITS AND AN EXTENSIVE LIST OF MEMBERSHIP SERVICES.

SWPA brings value in a changing world. Membership is your vital connection to industry trends, outlooks and new business opportunities. As a SWPA member, you’ll...

- ☞ Learn from your peers and expand your professional network.
- ☞ Interact and network with other industry leaders.
- ☞ Sharpen your skills and build relationships.
- ☞ Keep up with new laws and regulations and how they impact the industry.
- ☞ Assist in creating guidelines and tutorials that impact the industry.
- ☞ Increase your clout.
- ☞ Save time and money and find business partners.
- ☞ Anticipate and prepare for the future.
- ☞ Receive unique industry outlooks unavailable elsewhere.

The many benefits and services of SWPA membership are available to:

PUMP MANUFACTURERS - Business enterprises which are actively engaged in either the manufacture and sale of or the sale on substantially a nationwide basis in the United States of America of one or more Industry Products. (For membership purposes, SWPA defines Industry Products as: “*submersible wastewater pumps that can efficiently handle solids.*”)

COMPONENT AND ACCESSORY MANUFACTURERS - Firms, partnerships, corporations or other types of business enterprises which are actively engaged in the manufacturing of parts or equipment distributed on a nationwide basis for the types of submersible wastewater pumps manufactured by Pump Manufacturer members.

NON-MANUFACTURERS (ASSOCIATE) - Distributors, rep organizations, service stations, systems packagers, consulting engineering firms, trade publications and others providing services related to submersible wastewater pumps for municipal and industrial applications and/or who provide services to users of those products.

TO LEARN MORE ABOUT SWPA MEMBERSHIP OPPORTUNITIES, VISIT THE SWPA WEB SITE AT WWW.SWPA.ORG OR CONTACT SWPA HEADQUARTERS AT 847.681.1868.

INTRODUCTION

THE *SWPA Membership Roster and Product Reference Guide* presents basic industry information and information about the Association and its programs, services, and activities. In addition, it includes information about SWPA's member companies — the products the Association's Pump and Component Manufacturer Members sell and the services provided by SWPA's Associate Members (non-manufacturers), making this publication a true submersible wastewater pumping systems users' and specifiers' guide.

See page 4 for information about how to this publication, including the product codes used to identify the types of submersible pumps and component parts and accessories manufactured and sold by our Manufacturer Members as well as the codes used to identify the services related to Industry Products* provided by SWPA's Associate Members. This publication also includes industry information as well as information about SWPA's major programs and activities, as follows:

WHO WE ARE AND WHAT WE DO. This Guide contains descriptions of the Association's mission, objectives, purposes, and information about SWPA's distinguished history and long list of achievements as well as an account of how and why the Association is *"Forging the Future of the Submersible Wastewater Pump Industry"*.

THE SUBMERSIBLE WASTEWATER PUMP STORY. A brief

THE SWPA MEMBERSHIP ROSTER AND PRODUCT REFERENCE GUIDE IS PUBLISHED ANNUALLY AS A SERVICE TO THE SUBMERSIBLE WASTEWATER PUMP INDUSTRY. IT IS A SUBMERSIBLE WASTEWATER LIFT STATION AND GRINDER PUMP USER'S AND SPECIFIERS GUIDE TO THE INDUSTRY AND SWPA'S MEMBERS AND CONTAINS A WIDE VARIETY OF USEFUL INFORMATION.

description about how submersibles have come to dominate the municipal lift station market.

DRY PIT SUBMERSIBLES. An explanation of dry well submersibles and the distinct advantages they offer over conventional dry pit installations to both the installer and the user.

HOW "THE SYSTEMS APPROACH" OPTIMIZES PERFORMANCE. *"The Systems Approach"* is a method that promotes better design though more comprehensive understanding of how all the components in a system interact with each.

SWPA'S TECHNICAL RESOURCES. Created by knowledgeable industry experts, these include unique books, pamphlets, white papers, and other materials about submersible

*For Membership Purposes, SWPA defines Industry Products as "submersible wastewater pumps that can efficiently handle solids."

wastewater pumps and wastewater lift stations and grinder pumps and grinder pump stations.

SWPA'S EDUCATIONAL TRAINING PROGRAMS. Two times a year, SWPA holds their Pumping Systems and Controls Training Seminars. These two-day events are packed with educational, hands on training. Educational training is on a host of Industry specific topics and also includes keynote speakers and topic presenters who are leaders in the Water and Wastewater Industry. In 2013, the Program was expanded to include "200 Level" courses for those who wish to expand their knowledge and participate in more advanced, intense training. These programs may also qualify for CEU credits and attendees receive SWPA technical resources and a course manual that includes all of the presentations.

SELECTING SUBMERSIBLE PUMPS. – A primer describing the considered in selecting submersible wastewater pumps for municipal and industrial applications.

TEST STANDARDS APPLICABLE TO SUBMERSIBLE PUMP APPLICATIONS — There are a number of National Standards applicable to submersible pump applications. Most are American National Standards Institute (ANSI) documents, published by the Hydraulic Institute (HI).

SWPA'S "INDUSTRY COMMUNITY" — SWPA created its Associate Member category

See Introduction, Page 11

How SWPA Is “FORGING THE FUTURE OF THE SUBMERSIBLE WASTEWATER PUMP INDUSTRY”

AS THE ASSOCIATION IS “*Forging the Future of the Submersible Wastewater Pump Industry*” by publishing a wide range of technical resources, presenting unique educational training seminars, working with recognized Standards Setting Organizations, and offering other programs and services, it is creating new initiatives to meet today’s – *and tomorrow’s* – informational and training needs.

SWPA is *the industry’s leader* in providing accurate, up-to-date, technical information about:

- Submersible wastewater pumps and the component parts and accessories in lift stations using solids-handling pump systems.
- Grinder pump stations for residential and commercial applications and the component parts and accessories in those installations.

NOW IN ITS *fourth decade of service* to the submersible wastewater pump industry, SWPA is recognized as *the spokesperson* and the premier informational and training resource for the submersible pump segment of the wastewater industry and looks proudly upon its long legacy of service.

SWPA attained that status by creating and utilizing a comprehensive network of resources. By mobilizing those resources, The Association has built an impressive list of achievements and accomplishments.

THE SUBMERSIBLE WASTEWATER PUMP ASSOCIATION (SWPA) IS A NATIONAL TRADE ASSOCIATION REPRESENTING AND SERVING MANUFACTURERS OF SUBMERSIBLE WASTEWATER PUMPS FOR MUNICIPAL AND INDUSTRIAL APPLICATIONS, MANUFACTURERS OF GRINDER PUMPS FOR RESIDENTIAL AND COMMERCIAL APPLICATIONS, MANUFACTURERS OF COMPONENT PARTS AND ACCESSORIES FOR SUBMERSIBLE WASTEWATER LIFT STATIONS AND GRINDER PUMP STATIONS, AND FIRMS PROVIDING SERVICES TO USERS OF THOSE PRODUCTS.

SWPA’S DEDICATED MEMBERS and staff have worked diligently to position the Association as the premier resource for technical information on submersible wastewater lift station systems and grinder pump stations.

THE TECHNICAL INFORMATION created and distributed by SWPA is based on “*The Systems Approach*” and is intended to meet the needs of those who design, build, install, service, maintain and operate lift stations using solids-handling pumping systems in municipal and industrial applications and grinder pumps in residential and commercial applications.

“*The Systems Approach*” optimizes performance by promoting the proper design of a submersible pump lift station, which depends on many mutually inter-

dependent factors. This is accomplished by better understanding of wet well design, hydraulics, and all the components that make up these systems.

Within that context, our programs and activities are focused on these three areas:

INDUSTRY GUIDELINES – Working with Standards Setting and Code development organizations to encourage wider acceptance of submersible pumps in wastewater applications. These efforts are aimed at developing voluntary product guidelines for effective product use.

EDUCATION – Informing specifiers and users about the workings and benefits of submersible wastewater pumps, representing the interests of members of the Association in the public interest.

PROMOTION – Encouraging the use of submersible wastewater pumps in municipal and industrial applications to increase their acceptance and build the industry.

SWPA’S PUMP MANUFACTURER MEMBERS are manufacturers of submersible wastewater pumps for these markets. They represent the bulk of U. S. shipments of Solids-Handling, Dry Pit Submersible, and Grinder Pumps.

SWPA’S COMPONENT MANUFACTURER MEMBERS are manufacturers of component parts and accessory products for submersible pumps and pumping systems. They supply pump manufacturers as well as the after-

market.

SWPA'S ASSOCIATE MEMBERS are non-manufacturers who provide services related to Industry Products, including distributors, rep organizations, consulting engineers, systems packagers, service stations, and publishers.

SWPA IS the focal point of the industry's communications network, providing a forum for pooling of skills and know-how, and facilitating the exchange of information on common problems, issues and concerns.

SWPA MAINTAINS a data center, providing information to the trade and consumer press, industry-related business groups, users, and members.

SWPA SERVES the entire submersible wastewater pump industry. One of our most important goals is to increase the acceptance and sales of Industry Products.*

SWPA REPRESENTS its members with groups involved in the selection, installation, and use of Industry Products* — including engineers, specifiers, users, Standards Officials, and Code Authorities.

SWPA ASSISTS its members by providing information on subjects of general industry interest such as marketing trends and industry “drivers.”

SWPA IS and has been a leader in the growing submersible wastewater pump industry since its inception in 1976.

*For Membership Purposes, SWPA defines Industry Products as “submersible wastewater pumps that can efficiently handle solids.”

STRATEGIC PARTNERSHIPS – Most recently, SWPA has developed a series of Strategic Partnerships with other industry Associations, organizations, and publishers to help its members prosper and succeed.

In these Partnerships, the Association chooses to align itself with respected partners that are passionate about their respective organizations and committed to a wider range of influence through augmented networking opportunities. These relationships enhance SWPA’s membership and membership services and benefits by allowing the Association to offer more tools and contents to help them thrive and prosper.

We have a distinguished history, a wide ranging record of service and a long list of achievements and accomplishments including:

The Submersible Sewage Pumping Systems (SWPA) Handbook, 4th Edition (2012)

— a 248 page technical volume that was developed by a task force of industry experts. This unique publication familiarizes and assists those responsible for designing, installing, maintaining, and operating lift stations using submersible solids-handling pumps.

The Fourth Edition is expanded and revised. It includes a new chapter on Submersible Motors, an expanded chapter on Grinder Pumps in Pressure Sewers, a new chapter on valves, updated charts and tables and much more. The 4th Edition will also be released in Spanish in 2015

The *SWPA Handbook* has been “The Bible” of the industry since it was introduced in 1984 in a soft cover version. There is no better reference tool. It has been published in hard cover format since 1986. Since its launch, more than 30,000 copies have been distrib-

uted throughout the world.

The Handbook is available in e-book format on SWPA’s website at www.swpa.org.

PUBLISHING THE *Field Start-Up and Check-Out Procedures Manual for Submersible Sewage Lift Stations* -- A practical, 28-page text that presents step-by-step procedures, based on equipment available, for putting a new lift station into operation or tuning an existing stations...a distinctive “How To” guide with explanations for field personnel.

CREATING A *Statistical Reporting Program* that provides quarterly data on Solids-Handling, Dry Pit Submersible by discharge size, and Grinder Pump shipments by Horsepower, as well as semi-annual data on the destinations of those shipments.

PRODUCING AN *Annual Industry Outlook Survey* – Each Fall, SWPA conducts a survey of its members to gather information about expected industry performance for the coming year. Included are forecasts of pump shipments by types and sizes and projections for a wide range of component parts and accessories for submersible wastewater lift stations and grinder pump stations. The survey also solicits information on the expected “drivers” of industry sales, new product trends, and other information.

DISTRIBUTING “*The Very Versatile Submersible*” – A video training program that was created to inform viewers of the advantages and multiple uses of submersible wastewater pumping equipment.

This eight-minute course was designed for use at seminars,

schools, and other meetings and discusses some of the ways this versatile machine serves specifiers and users throughout the world.

PUBLISHING THE SWPA

Standardized Presentation Format for Pump and Motor Characteristics. The format includes the minimum information needed by a specifier or designer to adequately evaluate using specific equipment for an individual application.

Information is presented in a consistent format to the designer or specifier can make an informed comparison between different brands or types of equipment.

A series of standardized pump/motor definitions of the terms that the data represents is an important element of this SWPA Technical Resource.

CREATING A Grinder Pumps

in Pressure Sewers Committee whose mission is: *“To serve as a technical, marketing, and public relations information resource center to the membership, the industry, the marketplace, and the general public on grinder pumps in pressure sewer systems.”*

The Committee’s primary goals are to develop technically oriented products and services on pressure sewer systems and create and distribute marketing and public information materials such as these:

- A comprehensive **Press Information Kit** which includes a white paper entitled *“A Pressure Sewer Overview – A Proven Approach to Moving Wastewater from One Point to Another”*, a series of Frequently Asked Questions

(FAQ’s) and Answers about grinder pumps and pressure sewers; and a series of Definitions, Drawings and Common Terminology.

- **Grinder Pumps in Pressure Sewers**, a primer to raise the awareness and describe the advantages of these products and how they are used.
- A generic Training Presentation entitled *“An Introduction To Grinder Pumps In Pressure Sewers”* that can be used for a general information presentation or a training tool. This tutorial is posted on the SWPA web site (www.swpa.org) in a downloadable pdf format.

INTRODUCING *state-of-the-art educational training programs* where attendees hear and interact with industry experts in the same place, at the same time, and tap into their extensive experience and wide-ranging expertise.

SWPA’S SEMI-ANNUAL 2-DAY TRAINING SEMINAR IS DIVIDED INTO TWO SEPARATE, BUT COMPLIMENTARY TRACKS...THE PUMPING SYSTEMS TRAINING SEMINAR TRACK provides a comprehensive description of pumping system design and how the many components of a *total* submersible pumping system influence and affect each other. By attending these seminars, attendees learn better system design though understanding the impact of each component on the other and on the total system.

SWPA’S CONTROLS SYSTEMS TRAINING TRACK presents an up-to-date roadmap to the rapidly-changing world of pump station controls and control considerations.

This is an application and theory-oriented program where attendees learn to better understand the basics of lift station controls, control considerations and controls trouble-shooting.

The individual presentations provide technical information, address practical user concerns, describe common troubleshooting issues and present the tools available to solve them in existing or new control systems.

Since most pump systems last more than 15 years, excessive costs related to inefficiencies can accumulate if left unchecked. Optimum design and operation efficiency are in the best interests of all facilities using submersible pumps, which rely heavily on pumping systems for operation of critical processes.

Inefficient pumping systems can be large energy wasters. Effective maintenance and through system assessments can keep pumps performing at their best.

That is why both of these programs are based on *“The Systems Approach” to the Design, Construction, Operation and Maintenance.*

The overwhelming success of this unique, 2-day forum has allowed us to further expand the program to include a series of advanced topics. This additional Track will allow participants to take their learning to a higher level.

PRESENTING additional training programs on an “as needed” basis such as *“Hydraulic Design Of Rotodynamic Pumps — An Intensive Course For Hydraulic Pump Designers.”*

INTRODUCTION *Continued from page 7*

because it understands that it is in need of balanced input from the entire submersible wastewater pumping system “community” and that distributors, rep organi-

zations, service stations, systems packagers, consulting engineering firms, and others providing services related to Industry Products and/or who provide services to users of Industry Products represent a vitally important segment

of this “community.”

Additional copies of this publication in hard bound or electronic format are available upon request from SWPA Headquarters. The publication is also posted on the SWPA Web Site at www.swpa.org.

SWPA has once again partnered with *Pumps & Systems Magazine* to create the SWPA Training Resource Center, an on-line/on-demand video training curriculum accessible from either www.swpa.org or www.pumpsandsystems.com. Participants will earn SWPA Certificates of completion, which may be submitted for CEU/PDH credits. The site will also serve as a repository for Industry News and Articles, Technical Articles, Case Studies, SWPA Manuals, Handbooks, etc. as well as a calendar of SWPA events. All of this will be included in your SWPA Membership dues.

FREE TO SWPA MEMBERS!



Training Resource Center

- ✓ On-Demand Webinars
- ✓ CEU Credits
- ✓ Training Manuals
- ✓ Learning Resources

One Convenient Place

Online SWPA Training Resource Center

Your on-demand CEU & training headquarters

Courses

- The Systems Approach to Lift Station Design, Operation & Maintenance
- Grinder Pumps and Pressure Sewers
- Variable Frequency Drives
- Start-Up, Operation, Maintenance and Safety
- Pump System Optimization
- Cavitation and Air Entrainment – Advance Level Course
- Additional topics to be added: SCADA, Motors, Valves, Enclosures, Controls 101

Resources

- Industry News and Articles
- Technical Articles
- Case Studies
- SWPA Manuals, Handbooks, etc.
- Schedule of SWPA Events

brought to you by

PUMPS&SYSTEMS
THE WASTEWATER PUMPING INDUSTRY ASSOCIATION

SWPA



• Participates may earn Continuing Education Credits (CEUs)

ALL CONTENT FREE TO SWPA MEMBERS!

THE SUBMERSIBLE WASTEWATER PUMP STORY

SIXTEN ENGLESSON is credited with developing the first submersible wastewater pump in Sweden. That pump was manufactured in 1956 and had a discharge connection and level regulator. It became popular in the early 1960s, when a guide-rail system was developed to lift the pump out of well pits for easy maintenance and repair.

Submersible pumps offer these advantages:

- Low initial cost since they involve only one pit and less auxiliary equipment is required than for dry well/wet well installations.
- Low operating costs based on Life Cycle Costing (LCC).
- Safe and quiet installations.
- A minimum of unsightly above-ground equipment.
- Reliable operation over a long life.

A SUBMERSIBLE LIFT STATION includes not only the pump-motor unit, but also sophisticated electrical and mechanical controls, piping, and a wet well with access frame and cover.

Submersible pumps are also widely used to handle suspended solids effectively and efficiently.

SUBMERSIBLE SOLIDS-HANDLING WASTEWATER PUMPS operate under water, are flood-proof, and are designed for single, wet-pit use. They can be removed easily for maintenance. They operate efficiently and quietly, are safe to install, and perform reliably for many years.

These pumps are used primarily for wet-pit wastewater lift stations

ORIGINALLY USED IN EUROPE, SUBMERSIBLE WASTEWATER PUMPS BECAME POPULAR IN THE EARLY 1960S WHEN A GUIDE-RAIL SYSTEM WAS DEVELOPED TO LIFT THE PUMP OUT OF WELL PITS FOR EASY MAINTENANCE AND REPAIR.

THIS ENDED THE DIRTY AND SOMETIMES DANGEROUS TASK OF SENDING PEOPLE INTO THE WET PIT. SUBMERSIBLES ARE NOW THE DOMINANT PUMP IN THE MUNICIPAL LIFT STATION MARKET.

and for industrial sump or process effluent applications.

SUBMERSIBLE WASTEWATER PUMP MANUFACTURERS have improved the performance of their products to a very high degree, optimizing design as well as manufacturing techniques. Today, submersible wastewater pumps are highly efficient, extremely reliable, long-lasting machines.

One common use for small pumps is to move effluent from a tank to disposal in septic tank systems. Large and small units are used in a variety of ways in the home, farm, motel, school, marine, commercial building, industrial plant, and municipal wastewater and stormwater systems.

Submersible pumps have been proven over more than a half-century, disproving those skeptics who originally asked how an electric motor-powered pump "could run under water". Submersibles are now used around the world to pump clear water, raw water, and wastewater. *Millions are in daily use.*

GROWTH OF THE MARKET for submersible wastewater pumping equipment has since been dramatic, as an increasing number of specifiers and users learned of its advantages.

There are two classes of submersibles. One is the smaller unit, used in home and light commercial applications. These normally handle up to 2-inch spherical solids and range from 1/3 to 2 horsepower. These are commonly called "sewage ejectors".

Larger submersibles are discussed here. They handle 2-1/4 inch and larger solids and have a minimum of 3-inch discharge. They are used in municipal and industrial applications, for pumping all types of wastewater.

ADVANTAGE OF SUBMERSIBLES
Submersible wastewater pumps have a number of advantages to users.

ONE OF THOSE MAJOR ADVANTAGE IS LOW INITIAL COST. In wastewater pumping applications, only one pit is necessary, which reduces initial investment. There is no need, in most installations, for ventilation, lighting, or other equipment, which is normal for dry pits. Flooding problems are also eliminated.

A SECOND IMPORTANT ADVANTAGE IS LOW OPERATING COST. Compared to above-ground pumps, for example, submersibles are more efficient. Submersibles have the obvious hydraulic advantage of working in the water and not some distance above it. Submersibles never lose prime.

Submersibles have safety and noise reduction benefits, too, since the working installation is well below ground level. There is less chance for accidents from an exposed motor and there is a minimum of noise when the pump is operating.

WITH SUBMERSIBLE PUMP APPLICATIONS, there is a minimum of above-ground equipment -- usually only the control box and a frame for use in attaching the hoist for removal of the pumps. There is no unsightly pump or any need for a pump house.

Moreover, because wet wells are designed so incoming wastewater scours the bottom, there is little chance of emitting offensive odors.

BUT THE MOST STRIKING ADVANTAGES OF SUBMERSIBLES ARE RELIABILITY AND LONG LIFE. Submersibles are designed to operate efficiently under water. Submersibles run only when needed, reducing wear and power bills.

Suction pipe clogging and net positive suction head (NPSH) problems are also eliminated. The water cools the motor naturally, adding to its life span. Field service is simple and sure.

And, submersible pump manufacturers report that fewer than one-half of one percent of the pumps they ship are returned for replacement.

Submersible wastewater pumps are the fastest-growing products in the fast-growing wastewater and solids-handling field.

PUMP FEATURES. Here's an introduction to the selection and use of this fast-growing product.

Description: Submersible wastewater pumps are vertical,

direct-coupled, extra-heavy duty units, which operate under water and have a solids-handling capability.

While single pumps (simplex systems) are often installed, most applications require two pumps (duplex installations) to insure continued operation if one pump fails, to minimize wear on one pump and equalize it between two, and to provide extra capacity in times of extraordinary loads.

A submersible pumping system consists of the motor-pump unit together with automatic electrical controls.

SYSTEM CONTROLS. Controls can be simple or complex, depending on the application. The latter may consist of an entire factory-packaged station enclosed in a steel or fiberglass tank ready for installation and pipe-electrical hookup.

Submersibles are being specified increasingly in applications where self-priming, dry pit, straight centrifugal, vertical extended-shaft, and pneumatic ejector pumps once dominated.

Discharge Size: Depending on the impeller design, a 4-inch discharge pump will normally handle spherical solids from 2- to 3-inches.

Each manufacturer's literature specifies the maximum solids size, which can be handled by a particular pump. Normal discharge sizes for larger submersibles range from 3-inches to 14-inches and larger. The pump selected should be sized to the application.

Motors: Submersible pump motors can be sized to the application. They are normally available in 850, 1150, 1750, and even 3450 RPM designs, on 60-cycle power. Horsepower ratings range

up to 100 HP or larger.

Variable speed units are also available with the use of variable frequency and voltage power supplies. Again, depending on the application, motors operating on 200/208-volt, 230-volt, 460-volt, 575-volt and higher are available.

Motors may be single-phase or three-phase, as specified. Single-phase units are usually limited to 10 horsepower. Thus, submersibles can be tailored to specific requirements.

Capabilities: Like any pump, submersibles can also be tailored to the capacity requirements of the particular installation. For example, a specifier can ask for a high dynamic head, or can accept a lower head and obtain a higher gallons-per-minute flow rate - or can get both a higher head and a higher flow rate by increasing the horsepower rating.

Typically, dynamic heads range from 15 to 300 feet. Flow rates range from 10 to 2,500 gpm and larger pumps produce 10,000-gpm or more. The pump-motor unit can be tailored to installation needs. Many larger pumps can be used in conjunction with a variable speed drive (VSD) to further fit the performance to the application.

CONTROL PANELS are engineered for the particular installation. The heart of the control system for submersibles is the liquid level control, which activates and deactivates the pump(s) at specified levels within the wet well.

The simplest control system contains an On-Off magnetic contactor and disconnect. Systems normally have three sets of controls -- one for turning off the first pump, one for turning on the pump, and one for the high liquid alarm.

Duplex systems usually alternate pumps on each successive cycle. Duplex systems may also include an override control, which brings in the second pump when in-flow is unusually heavy or in case of failure of the first pump.

Control panels are installed above ground, and usually contain: pump disconnects; across-the-line starters with overload protection; hand-off-automatic selectors, elapsed time meters, and alarm systems for indicating high level conditions in the wet-well.

In addition, duplex systems provide for automatic sequencing and alternating of pumps.

Alternation allows for equal run time and wear of the pumps. Alarm systems vary but can be visual, audible or remote monitoring by telemetry devices or telephone lines.

PUMP MANUFACTURERS will assist designers determine which con-

trols are needed for a particular application, and then manufacture the control panel to this specification. All are built to NEMA (National Electrical Manufacturers Association) Standards and in accordance with the NEC (National Electric Code).

Wet pit installation is a major advantage of submersible wastewater pumps. Only one pit is required. The pump is usually installed on guide rails.

SERVICING. If field service or replacement is needed, the pump is easily lifted to the surface using guide rails.

When lowered into position, the pump outlet flange automatically seats with the discharge piping. There is no need for wrenches, special tools, or for anyone to enter the pit.

Most submersibles can be serviced in the field without disturbing the piping. This represents a

major cost savings to the user.

Complete packaged wastewater lift stations are available. These packages include everything from the tank to the pump-motor unit, guide rails, piping and valves, all controls, etc. – and are shipped ready for installation.

Access frames and covers are available for either wet pit or sump allocations. They are designed so the cover can be locked safely in the open or closed position.

Traffic-bearing covers are also available.

Many submersible pumps are being used as replacements in older systems.

For example, numerous submersible pumps were used to replace typical, non-submersible centrifugal pumps after events like Hurricane Katrina at wastewater treatment plants and pump stations in the New Orleans area.

SELECTING SUBMERSIBLE PUMPS

SUBMERSIBLE CENTRIFUGAL PUMPS come in different designs, each with specific characteristics and capabilities to meet various operating conditions. Pump capacity is determined primarily by the speed, size, and design of its impeller, which creates liquid head and flow through its rotating motion. Other factors in capacity are friction, leakage, and shock losses. The volute -- or stationary part of the pump -- guides the liquid being pumped through the discharge opening. The size of the impeller passages and the clearance between the impeller and the volute allows for the passage of solid particles in the liquid.

When pumping wastewater, a major design criteria is the ability of the pump to pass solids. Submersible wastewater pumps are often rated by the maximum size of a solid that they can pass (“sphere size”). This is a very rough measure of a pumps’ ability to handle solids bearing liquids, in that the type and quantity of solids varies considerably between liquids. Most solids found in wastewater are compressible and can easily be broken apart, therefore limiting the value of the “sphere size” criteria. Until a standardized test for solids bearing liquids has been developed, user experience is the best base for matching a suitable pump design to an application.

The design of the approach piping and the sump should be done in a manner to minimize the deposition of solids. A minimum approach flow/velocity of about 2.5 ft/sec (0.8 m/s) is required in the suction piping to prevent solids from settling and combining with other solids to form a larger solid with a size capable of clogging the pipe, valve, or pump.

DRY-PIT SUBMERSIBLES

SUBMERSIBLE PUMPS, originally developed for use in applications where the pump unit will be submerged in the pumped liquid, are now widely used in dry well stations where the wet well is separated from the dry pump chamber.

DRY WELL SUBMERSIBLES offer distinct advantages over conventional dry pit installations to both the installer and the user. Their compact design, installation versatility, and resistance to damage from flooding make them ideal for use in both new and retrofit pumping stations.

In today's challenging environment, municipalities are faced with financial issues due to an aging infrastructure and a reduction in service personnel due to funding reductions from federal, state, and local budgets.

Large pump stations are typically the conventional dry-pit / wet-pit design with a motor located floors above the pump connected by a shaft.

This design requires increased manpower for maintenance and can present problems with excessive vibration to the pump, motor, and structure. The dry-pits are prone to flooding as evidenced by the weather in recent years.

Manufacturers have designed a submersible motor that will run wet or dry, require little or no maintenance and with no vibration problems for the pump station.

DRY-PIT SUBMERSIBLES offer municipalities reduced initial costs, reduced installation costs, and reduced maintenance costs when used as a replacement for conventional dry-pit / wet-pit

SWPA DEFINES A DRY PIT SUBMERSIBLE PUMP AS: A SUBMERSIBLE PUMP, ORIGINALLY DEVELOPED FOR USE IN APPLICATIONS WHERE THE PUMP UNIT WILL BE SUBMERGED IN THE PUMP LIQUID, BEING USED IN A DRY WELL STATION WHERE THE WET WELL IS SEPARATED FROM THE DRY PUMP CHAMBER.

solids handling line shaft pumps. Dry-pit submersibles are also more efficient and more reliable.

DRY-PIT SUBMERSIBLES also offer installation advantages: submersible motor that will run wet or dry, require little or no maintenance and with no vibration problems for the pump station.

DRY-PIT SUBMERSIBLES offer installation advantages:

- No damage from flooding.
- No vertical shafting.
- No coupling alignment.
- No packing or seal water leakage.
- No seal water.
- No hazardous rotating components
- No dry well cooling.

DRY-PIT SUBMERSIBLES also offer system advantages:

- Simpler controls.
- More frequent starts allowed.
- Wider range of operation.

- Reduced vibration.
- Simpler support design.
- Increased utilization of available space.
- Elimination of shaft losses.
- More efficiency.

SWPA MEMBERS REPORT that the dry pit submersible pumps being purchased today are getting larger in horsepower and discharge sizes and that coastal users are purchasing more and more of these products because of storm drainage.

Ideal for either new stations or retrofitting existing stations, dry pit submersibles offer unmatched versatility and flexibility for wastewater pumping stations. Their compact, self-contained design offers significant savings in installation costs over conventional, coupled dry pit pumps.

The fully submersible, integrated motor offers trouble-free pumping, even in the event the dry well is flooded. With a wide range of sizes, motor powers, and impeller types available, dry pit submersibles offer alternatives to conventional, coupled pumps in nearly every type of wastewater pumping application.

IN SUMMARY, dry-pit submersibles offer reduced initial costs, reduced installation costs, and reduced maintenance costs when used as a replacement for conventional dry-pit / wet-pit solids handling line shaft pumps. Dry-pit submersibles are also more efficient and more reliable.

“THE SYSTEMS APPROACH”

SUBMERSIBLE WASTEWATER pump manufacturers have improved the performance of their products to a high degree, optimizing design and manufacturing techniques. Today, submersible wastewater pumps are highly efficient, extremely reliable, long-lasting machines.

Submersible wastewater pumps, which are often purchased as individual components, provide a service only when operating as part of a total system. The proper design of that system — a submersible pump lift station — depends on many mutually dependent factors because these pumping stations are complex and their design requires considerable engineering expertise. By better understanding wet well design, hydraulics, and all of the components that make up these systems, “bottom-line” performance is optimized.

“THE SYSTEMS APPROACH” encourages careful analysis of the end-use requirements to determine if the pump and each of the system components is efficiently sized and configured to meet the end use-requirements; screening the system to help optimize improvement opportunities; calculating life cycle costing for maximum energy efficiency; and finding symptoms that could lead to inefficiencies.

THE PUMP’S TASK -- All pumping systems are comprised of a pump, driver, pipe system, and operating controls. The pump’s task in the system is to deliver a liquid through pipes or ducts to a remote point against the system

“THE SYSTEMS APPROACH” OPTIMIZES PERFORMANCE BY PROMOTING THE PROPER DESIGN OF A SUBMERSIBLE PUMP LIFT STATION, WHICH DEPENDS ON MANY MUTUALLY INTERDEPENDENT FACTORS. THIS IS ACCOMPLISHED BY BETTER UNDERSTANDING OF WET WELL DESIGN, HYDRAULICS, AND ALL THE COMPONENTS THAT MAKE UP THESE SYSTEMS.

pressure.

When transporting fluid, the pump installation is sized to handle a maximum flow, which, in practice, often never occurs. The energy and materials consumed in accomplishing this task depend on the design of the pump, the design of the installation, and the way the entire system is operated and maintained.

TO UNDERSTAND a complex pumping system like a submersible wastewater pump lift station, *it must be realized that all of the system components are interdependent and must be carefully matched to each other and remain so throughout their working lives.* Those system components typically include the source and designation sumps or tanks, individual pipelines, pumps, valves, and items that control the rate or direction of flow.

This is why one of SWPA’s strategic initiatives is to expand its publishing and educational activities and promote “*The Systems Approach*” when designing, maintaining, operating, and

maintaining a submersible wastewater lift station.

MOST OF THE ASSOCIATION’S current technical resources describe the components of a lift station and how they work. These descriptions are being expanded to include detailed information on how the components are integrated into the system and how they interact with the other parts and pieces to make the total system work to peak efficiency and effectiveness. In addition, these current descriptions are being expanded to explain how each component affects the others such as the valves’ affects on the pump and the pump’s affect on the valves.

By publishing and promoting “*The Systems Approach*” information, SWPA is helping consulting engineers, specifiers, users, and others gain a better understanding of the pump, valves, control panels, VFDs, basins, mechanical seals, and other components and how they interact for optimum performance, minimum maintenance, and long life.

THIS FOCUS ON SWPA’s “*Systems Approach to Lift Station and Grinder Pump Station Design, Operation and Maintenance of Submersibles*” is encouraging and promoting better system design through a more comprehensive understanding of the impact of each component on each other and on the total system.

SWPA’s efforts in this area are helping consulting engineers, specifiers, users, and others identify and understand what they must know about the total

system to select the proper components for a given design.

BENEFITS OF “THE SYSTEMS APPROACH” – “*The Systems Approach*” promotes proper design by:

- Determining the proper horsepower and impeller sizing of pumps.
- Determining the proper power requirements.
- Sizing the wet well, frame and covers, valves, and other ancillary equipment.

“*The Systems Approach*” determines system responsibility because:

- Complex systems with multiple component parts such as pumps, control systems, valves, and special start/stop units require unit responsibility.
- Unit responsibility eliminates the questioning of cause of failure and isolates it under a single source.
- Reduces the time element for repairs.

“*The Systems Approach*” optimizes performance of the pumping system because it assures that the matching of multiple pieces of equipment will operate to provide the best performance.

“*The Systems Approach*” establishes a standard format for submittals and approvals since it:

- Provides standard pump charts.
- Provides pump test standards.
- Provides engineering, application and operations manuals.

“*The Systems Approach*” assures matching multiple pieces of equipment for optimum performance.

ENGINEERING AND APPLICATION MANUAL – This information is being incorporated into the development of a comprehensive manual, to be known as the *SWPA Submersible Wastewater Pumping Systems Manual (Engineering, Applications and Components Integration for Use in Submersible Wastewater Pump Stations)*

It will be produced in sections, and offered in a ring binder and on CD, with each section capable of being used as a textbook, as a users’ daily reference manual, or as training material.

The specific objectives of the project are to develop and present technical materials to consulting engineers, specifiers, and users, that provides a comprehensive description of how all the components of a total system impact and affect each other, including, but not limited to:

- Functionality of a submersible pump.
- System planning and sizing.
- Pressure sewer system guidelines.
- Specifications, layout drawings, and system application information.
- System components and how each impacts with the other components in the system.
- Wet well and dry well considerations.
- Odor control.
- Conventional and alternative treatment systems.

- Startup.
- Operation and maintenance.
- Alternative uses for submersibles.
- Safety.
- Station tune-up
- Wastewater quality.

COMPONENT STANDARDS AND GUIDELINES – Developing test standards and performance and design guidelines for each component of a lift station and presenting educational training programs about each will be an integral part of these efforts in the years ahead.

SWPA WILL CONTINUE its strategic initiative of creating Technical Resources promoting and focusing on “*The Systems Approach*” by working closely with established Standards and Code development organizations to create new Test Standards as well as performance and design guidelines for all of the components of a submersible lift station and grinder pump station. These efforts will be aimed at developing voluntary product guidelines for effective product use.

The Association continues to work with Code development organizations to insure the Industry’s needs are met.

“*The System’s Approach*” is also being used as the basis for the Association’s expanding educational and training programs, including its Semi-Annual Pumping Systems Training Seminar and Controls Training Seminar as well as its on-line training programs.

EDUCATIONAL TRAINING PROGRAMS

AS AN ESSENTIAL ELEMENT of its strategic initiative to promote “*The Systems Approach*” (see page 16), SWPA’s comprehensive educational and training programs focus on this approach.

SWPA and *Pumps and Systems Magazine* produce a multi-part webinar series on the systems approach to lift station design. CEU/PDH credits will be issued for completion. The webinars will be presented free of charge. For more information, contact SWPA Headquarters at 847-681-1868 or visit www.swpa.org.

SEMI-ANNUAL PUMPING SYSTEMS TRAINING SEMINAR – Following its introduction in 2002 SWPA’s Pumping Systems Training Seminar fast became an industry event, attracting consulting engineers, designers, specifiers, users, distributors, reps, product managers, technical managers, engineering managers, sales and marketing managers, product specialists – and many others with an interest in the design, applications, and use of submersible wastewater pumping systems for municipal and industrial applications from as far away as Alaska, Mexico and Puerto Rico.

This one-of-a kind program presents a comprehensive description of pumping system design and how the components of a *total system* influence and affect each other.

The proper design of these systems depends on many mutually dependent factors because they are complex and require considerable engineering expertise.

AS AN ESSENTIAL ELEMENT OF ITS STRATEGIC INITIATIVE TO PROMOTE “THE SYSTEMS APPROACH” SWPA PRESENTS TWO SEMI-ANNUAL TRAINING SEMINARS – A PUMPING SYSTEMS AND CONTROLS TRAINING SEMINAR, AS WELL AS A NEW, STATE-OF-THE-ART ON-LINE/ON-DEMAND TRAINING RESOURCE CENTER THROUGH A PARTNERSHIP WITH *PUMPS & SYSTEMS MAGAZINE*.

Attendees learn about better system design through understanding the impact of each component on the other and on the total system.

The featured presentation that sets the stage for the entire program is entitled “*The Systems Approach* to question: “*What is The Systems Approach*” and *Construction*, describes, in *Lift Station Design, Operation and Maintenance*.” This presentation answers the details, how it benefits the design engineer, manufacturer, sales representative, contractor, *and* the end user. The program typically includes sessions such as these:

LIFT STATION VALVING – The session addresses the design and selection of check valves, air valves, and plug valves for wastewater lift stations. The types of valves on the market is examined and, more importantly, how they interact within the system is analyzed.

MECHANICAL SEALS FOR SUBMERSIBLE MOTORS – Attendees learn about the use of mechanical seals as they apply to

submersible wastewater pumps... the typical installation of seals as it relate to submersible pumps; basic seal components and terminology; seal styles and types; standard mechanical seal materials, and common causes for mechanical seal failures.

AC MOTORS FOR SUBMERSIBLE PUMPS – The focus of this session is on the construction, rating, and application of submersible motors...motor construction features including basic design of the motor, winding and insulation materials, and cooling systems ... motor ratings such as efficiency, power factor, torque, etc...explosion proof motors, and insulation classes.

ELECTRICAL STARTING METHODS FOR SUBMERSIBLE PUMP STATIONS – During this session, attendees learn the considerations for the selection of electrical starting equipment for submersible pump systems. The most practical approaches of direct across the line start, reduced voltage, and variable speed systems as they relate to “The Systems Approach,” are emphasized.

APPLYING VARIABLE FREQUENCY DRIVES (VFDS) TO SUBMERSIBLE PUMPS – This session describes how pumps operate in variable speed applications and what is critical for successful variable speed pump stations. Discussions focus on the proper pump selection, potential for energy savings, rules of thumb for VFD applications, NEMA MG1 part 31 requirements and other aspects of applying VFDS to submersible

motors.

PUMP STATION CONTROL

CONSIDERATIONS – The typical elements of pump control panels and an overview of components and options available is presented.

AN OVERVIEW ON THE BASICS OF PLC CONTROLS – Attendees learn how they are used, how they come about, and where they're going. This session also provides an introduction to PLC technology by illustrating its evolution from its earliest beginnings to its modern state. Also provided is insight into where the field is going, and what can be expected. Included in this session is a discussion of benefits, applications, HMI, SCADA systems, common networks, and the IEC-61131-3 Program Standard.

DESIGN EXAMPLE – This session puts it all together by presenting a step-by-step example of how-to design a typical, small, circular wet well pump station.

GRINDER PUMPS IN PRESSURE SEWERS – A primer to raise the awareness and describe the advantages of these products and to report on how they are used.

CASE HISTORIES – During this session, representatives from SWPA member pump and component manufacturer member companies – the industry's leaders – describe particularly challenging or unusual installations.

SEMI-ANNUAL CONTROLS TRAINING SEMINAR – SWPA introduced its Second Annual educational and training program

– *A Controls Training Seminar* – in 2008. This in-depth program is designed for water and wastewater pump station service personnel, pump station operations personnel; water and wastewater service personnel who work with submersible wastewater pumping systems on a daily basis and those who work for Pump/ Rep Service organizations.

This is also an ideal educational opportunity for representatives of submersible pump manufacturers, submersible lift station component manufacturers, distributors, service shops, and consulting and specifying engineers who need a better understanding of the basics of controls and controls troubleshooting.

To gain the most from this program, attendees should have a basic knowledge of controls.

This Program is application and theory oriented and is beneficial to anyone who needs to understand the basics of lift station controls, controls applications, and controls troubleshooting. The individual presentations provide essential technical information, address practical user concerns, describe common troubleshooting issues and the tools available to solve those issues in control systems already installed as well as updates to existing systems and planned new systems and feature demonstrations, hands-on problem-solving and start-up procedures.

Attendees learn about State-of-the Art Control Systems and control considerations to give water and wastewater operators and engineers *total* command over their systems that was unimaginable only a few short years ago.

This modern pump and controls technology can help municipalities weather economic crisis and save precious dollars.

SWPA's Controls Training Seminar, too, is a one-of-a kind program and provides a an up-to-date roadmap to the rapidly-changing world of pump station controls and control considerations and related topics.

The featured presentation that sets the stage for this program is also on "The Systems Approach" but focuses on controls and control considerations.

The program typically includes sessions such as these:

SCHEMATIC TRAINING, SYMBOLS, AND TROUBLESHOOTING – An introductory look into reading and interpreting electrical schematics. Topics covered include basic electrical theory, definitions of common schematic symbols and their usage, and schematic notation standards. Techniques for troubleshooting a control system using the electrical schematic presented.

ENCLOSURE SOLUTIONS THAT FACTOR IN THE ENVIRONMENT – This session highlights many enclosure solutions Attendees may not have thought of before but after participating in this session, will help be better prepared to select the best enclosure at the best price for the application and environment required.

MOTORS, MOTOR STARTING OPTIONS AND MOTOR PROTECTION ALTERNATIVES – This session begins with an overview that helps Attendees understand AC motors and AC motor

operations and teaches them how to evaluate motor ratings, including efficiency, power factor, torque, etc. Other important motor and motor-related covered include motor compatibility with controls, motor starting options and motor protection.

VARIABLE FREQUENCY DRIVES (VFDS) WITH SUBMERSIBLE PUMPS – Its all about energy ... and so much more. Learn how submersible pumps, like most pumps, are being controlled from VFDs which serve multiple purposes for most applications including speed regulation and help eliminate or reduce inrush current which helps save energy. This session also teaches how today's VFDs are getting smarter then ever before in that they can offer application specific functions, including constant pressure or constant flow control and pumping protection.

TYPES OF CONTROLS/CONTROL DEVICES – This session reviews and describes devices used inside control panels as well as external devices, types of controls including components typically found in control panels such as phase monitors, alternators, electronics, etc. and their application plus troubleshooting approaches and troubleshooting techniques for these controls and control devices.

PROGRAMMABLE LOGIC CONTROLLERS (PLC) AND THEIR APPLICATIONS – Building a control architecture on a stable platform that can be scaled to the application requirements is critical in Life Cycle Cost management, reliability, maintainability, and overall system viability.

This session also covers key areas of PLC/Process Control

applications, the interconnectivity required, and the benefits of a consistent control platform, across the water system enterprise.

DEDICATED PUMP CONTROLLERS

– This session begins with an explanation of the term “Dedicated Controllers” and then goes on to address selection criteria and discusses advantages and disadvantages of using a dedicated pump controller.

PUMP STATION MANAGERS, COMMUNICATIONS AND SCADA

– This session is divided into three distinct sections: The first focuses on the key characteristics of a pump station manager and when to use these types of controllers. During the second section, we discuss the various types of communications to a pump station control system. The final segment presents an overview of the key components of a SCADA system.

START-UP AND TUNING A STATION

– This is a wrap-up session that addresses mechanical and electrical issues such as generator testing, the pump end, level measurement, starter types, tuning to minimizing starts and stops and forcing alternatives, the required paperwork for starting and/or tuning a station, and related issues. As a reference tool, Attendees receive a complimentary copy of SWPA's *Startup & Field Check-Out Procedures Manual for Submersible Sewage Lift Stations*. **AS A RESULT OF PREVIOUS YEARS' SUCCESS, SWPA HAS COMBINED BOTH PROGRAMS INTO A SEMI-ANNUAL, MULTI-DAY FORUM** – Attendees hear and interact with numerous experts and their peers in the same place, at the same time, and tap into their *exten-*

sive experience and wide-ranging expertise. SWPA Technical Resources are provided and there's a special Media Area.

CEU CREDITS ARE AVAILABLE

– SWPA issues certificates to Attendees at its Annual Pumping Systems Training Seminar and its Annual Advanced Controls Training Seminar for completion of the course for submission to their respective state agencies for CEU credits.

TECHNICAL RESOURCES ARE INCLUDED

– Included in the registration fees for SWPA's two Annual Training Seminars are copies of the Associations' applicable Technical Resources AND an a comprehensive Attendee Book with Session Summaries, Speaker Biographies and contact information, their PowerPoint Presentations, and other Industry information and information about the Association.

SPECIAL MEDIA AREA OFFERED

– There is also a special “Media Area” at each of SWPA's Semi-Annual Training Seminars where SWPA's Pump Manufacturers and Component Parts and Accessory Manufacturers display their products and provide complimentary product literature and other resource information related to the programs' contents.

IN ANOTHER expansion of its educational and training programs in support of "The Systems Approach," SWPA has expanded its partnership with *Pumps & Systems Magazine* and created the SWPA Training Resource Center (TRC). The SWPA TRC is an on-line/on demand technical

resource that includes video curriculum on such Important Industry topics as: The Systems Approach to Lift Station Design, Operation & Maintenance, Grinder Pumps & Pressure Sewers, Variable Frequency Drives (VFD's), Pump System Optimization, Cavitation and Air Entrainment — an advanced course, SCADA — an advanced course, Motors, Valves, Safety and Enclosures, Controls 101,

and more. SWPA members can view these 1-hour Training Videos, complete with Q&A at the end and the ability to send SWPA additional questions free of charge. Non-members will pay a fee. Once a course is completed, SWPA will issue a Certificate of Completion, which you may submit to your local governing body for CEU/PDH Credits.

The site also includes Industry

News and Technical Articles, Case Studies, SWPA Manuals, handbooks and more.

REGISTRATION FORM

COMPLETE AND RETURN THIS FORM AND WE'LL ADD YOU TO OUR DISTRIBUTION LIST TO RECEIVE INFORMATION ABOUT SWPA'S UPCOMING TRAINING SEMINARS AND OTHER EVENTS AS WELL AS NOTICES ABOUT NEW TECHNICAL PUBLICATIONS AND SPECIAL OFFERS FOR EXISTING PUBLICATIONS.

NAME _____ TITLE _____

COMPANY _____

ADDRESS _____ CITY _____ STATE _____ ZIP _____

PHONE _____ FAX _____

E-MAIL ADDRESS _____

Company Description (Please check the appropriate box(es) so we can better Serve you:

- End User
- Service Shop
- Consulting/Specifying Engineer
- Distributor

- Rep Organization
- Systems Packager
- Pump Manufacturer
- Component Manufacturer
- Other, please specify _____

Use this space to tell us about subjects, topics, speakers and other elements you would like to see SWPA include during future Training Seminars, including subject matter for additional future programs:

STANDARDS FOR SUBMERSIBLE PUMP APPLICATIONS

APPROVAL OF AN AMERICAN NATIONAL STANDARD requires verification by ANSI (the American National Standards Institute) that the requirements of due process, consensus, and other criteria for approval have been met by a Standards developer. Consensus is established when, in the judgment of the ANSI Board of Standards Review, substantial agreement has been reached by directly and materially affected interests.

Consensus requires that all views and objections are considered, and that a concerted effort has been made toward their resolution. The use of an American National Standard is completely voluntary. The ANSI Canvas process requires that a Standard be reaffirmed on a five-year cycle.

THE ANSI/HI STANDARD FOR SUBMERSIBLE PUMP TESTS (ANSI/HI 11.6-2012) provides valuable information on procedures for centrifugal submersible pump performance testing.

ANSI/HI 11.6-2001 was developed through collaboration between SWPA and the Hydraulic Institute (HI). This Standard was created to meet one of the long-standing, major challenges in the wastewater pump industry: *the development and acceptance of a test standard written specifically for submersible pumps*. It was updated in 2012.

ANSI/HI SUBMERSIBLE PUMP TESTS primarily apply to tests of centrifugal submersible pumps driven by induction motors. Fundamentally based on the

THERE ARE A NUMBER OF NATIONAL STANDARDS APPLICABLE TO SUBMERSIBLE PUMP APPLICATIONS. MANY ARE AMERICAN NATIONAL STANDARDS INSTITUTE (ANSI) DOCUMENTS, PUBLISHED BY THE HYDRAULIC INSTITUTE (HI).

ANSI/HI Centrifugal Pump Test Standard (ANSI/HI 11.6), this Standard was initiated by a SWPA Test Standards Subcommittee, was processed and approved for submittal to ANSI by HI, and is now accepted and utilized by all segments of the pump industry.

The Standard underwent review in accordance with ANSI's five-year review procedures, and after 6 years, the updated test standard was officially issued in 2012.

ANSI/HI 11.6-2001, 2012 SUBMERSIBLE PUMP TESTS, describes submersible pump tests and covers terminology and these types of tests:

- Performance test.
- Hydrostatic test.
- Net Positive Suction Head (NPSH) test.
- Submersible motor integrity test
- Vibration test.
- Instrumentation.
- Model test.

The Appendix to the Standard presents formulas and examples.

For further information about this Standard and others listed on

these pages, contact the individual sponsoring organizations at the addresses and web sites listed on page 24.

SOME OTHER ANSI/HI STANDARDS THAT APPLY TO ROTODYNAMIC (CENTRIFUGAL) PUMPS INCLUDE:

ANSI/HI NUMBER/NAME OF STANDARD:

1.1-1.2 – Centrifugal Pumps for Nomenclature and Definitions.

1.3 – Rotodynamic (Centrifugal Pumps for Design and Application.

1.4 – Centrifugal Pumps for Installation, Operation and Maintenance.

1.6 – Centrifugal Pump Tests.

5.1-5.6 – Sealless Centrifugal Pumps for Nomenclature, Definitions, application, operation and Tests.

9.1-9.5 -- Pumps – General Guidelines for Types, Definitions, Application, Sound, Measurement and Decontamination.

9.6.2 – Centrifugal and Vertical Pumps for Allowable Nozzle Loads.

9.6.4 – Centrifugal and Vertical Pumps for Vibration Measurement and Allowable Values.

9.6.5 – Centrifugal and Vertical Pumps for Condition Monitoring.

9.6.7—Effects of Liquid Viscosity on Rotodynamic Pump Performance.

9.8 – Pump Intake Design.

11.2-12.6 –Rotodynamic (Centrifugal) Slurry Pump (Including Slurry Pump Test)

FACTORY MUTUAL (FM) STANDARDS are typically used for explosion proof pumps.

COMPONENT AND OTHER STANDARDS – There are also Standards that apply to Component parts and accessories for submersible pumps and solids-handling lift stations as well as for grinder pumps in pressure sewer systems and the component parts and accessories in those installations. These include

VALVE STANDARDS

THE AMERICAN WATER WORKS ASSOCIATION (AWWA) publishes the following Standards that apply to Valves used in Pumping Systems.

- **ANSI/AWWA C504-06, RUBBER-SEATED BUTTERFLY VALVES**
- **ANSI/AWWA C507-05, BALL VALVES**
- **ANSI/AWWA C512-07, AIR VALVES**
- **ANSI/AWWA C517-05, ECCENTRIC PLUG VALVES**
- **ANSI/AWWA C518-01, SWING CHECK VALVES**
- **ANSI/AWWA M51, MANUAL OF PRACTICE FOR AIR VALVES**
- **ASME B16.10, FACE-TO-FACE AND END-TO-END DIMENSIONS OF VALVES**

THE MANUFACTURERS STANDARDIZATION SOCIETY (MSS) publishes the following Standard that applies to Valves used in Pumping Systems.

- **MSS SP-58, PIPE HANGERS AND SUPPORTS**
- **MSS SP-71, GRAY IRON SWING CHECK VALVES**
- **MSS SP-92, MSS VALVE USER GUIDE**

- **MSS SP-96, GUIDELINES ON TERMINOLOGY FOR VALVES AND FITTINGS**
- **MSS SP-128 DUCTIBLE IRON GATE VALVES**
- **MSS SP-136 DUCTIBLE IRON SWING CHECK VALVES**

CONTROL PANEL STANDARDS -- Here's a brief summary of the primary Standards and Codes used by SWPA Member Control Panel Manufacturers that are applicable to Industrial Control Panels.

UL508A is titled Industrial Control Panels (published by Underwriter's Laboratories). The requirements in this Standard cover industrial control panels intended for a variety of uses. It covers panels intended to be installed in ordinary (non hazardous) locations in accordance with the National Electric Code (NEC) (NFPA 70).

THE CANADIAN STANDARDS covering these same types of panels are C22.2 No 14-M95 Industrial Control Equipment, C22.2 No. 94-M91 Special Purpose Enclosures, and C22.2 73-1953 Electrically Equipped Machine Tools and published by the Canadian Standards Association (CSA).

INDUSTRIAL CONTROL PANELS that are intended to be installed in hazardous locations as defined by the NEC must meet an additional set of requirements. These requirements are defined in UL Standard UL698.

PANELS that are not installed in a hazardous location, but have circuit extensions that go into hazardous locations, are covered by

UL698A. The hazardous locations covered by this standard are Class I, II, III Division I hazardous (classified) locations as defined by NEC article 500. The circuit extensions that go into hazardous locations are typically control circuits. This Standard requires the panel to include intrinsically safe and physical barriers for separation of the circuits that are going into the hazardous location.

NEC ARTICLE 500 covers electrical requirements for equipment and wiring for hazardous (classified) locations, Class I, II, and III.

NEC ARTICLE 409 is titled Industrial Control Panels and contains requirements for industrial control panels for general use. This article does contain references to other applicable NEC articles. For example article 409 references article 500 – 505 for equipment in Hazardous (classified) locations.

THE NEC may require equipment to be listed and labeled. This means that the product must be reviewed and approved by an organization that is acceptable to the authority having jurisdiction and meets other requirements spelled out in the NEC. Organizations such as UL, CSA, TUV, ETL and others meet these requirements. These organizations require the listed equipment to have a label which identifies the organization which provided the approval.

A list of the major Standards Setting Organizations whose work impacts on SWPA, its members and the submersible wastewater pump industry appears on the following page:

STANDARDS SETTING ORGANIZATIONS

LISTED BELOW ARE THE MAJOR STANDARDS SETTING ORGANIZATIONS WHOSE WORK IMPACTS ON SUBMERSIBLE WASTEWATER PUMPS, LIFT STATIONS AND THEIR COMPONENTS AS WELL AS GRINDER PUMPS IN PRESSURE SEWERS FOR RESIDENTIAL AND COMMERCIAL APPLICATIONS AND THEIR COMPONENT PARTS AND ACCESSORIES. FOR ADDITIONAL INFORMATION ON APPLICABLE STANDARDS, CONTACT THESE ORGANIZATIONS DIRECTLY.

ASMA – AMERICAN SOCIETY OF MECHANICAL ENGINEERS

Three Park Ave., New York, NY 10016-5990
Phone: 212/591-8530 | Fax: 212/591-7196
Web Site: www.asme.org

ANSI – AMERICAN NATIONAL STANDARDS INSTITUTE

25 W. 43rd Street, 4th Floor, New York, NY 10036
Phone: 212/642-4980 | FAX: 212/302-1286
Web Site: www.ansi.org

AWWA – AMERICAN WATER WORKS ASSOCIATION

666 West Quincy Avenue, Denver, CO 80235-3098
Phone: 303/794-7711 | FAX ; 303/347-0804
www.awwa.org

CSA – CANADIAN STANDARDS ASSOCIATION

178 Rexdale Boulevard, Toronto, Ontario, Canada M9W 1R3

Phone: 416/747-4000 | FAX: 416/747-4149
Web Site: www.csa-intl.org

Conformance to applicable CSA Standards is required in Canada for virtual all Standards is required to sell in that country

FM – FACTORY MUTUAL RESEARCH CORPORATION

1151 Boston-Providence Turnpike, P. O. Box 9102
Norwood, MA 02062

Phone: 781/762-4300 | FAX: 781/762-9375
Web Site: www.fmglobal.com

HI – HYDRAULIC INSTITUTE

6 Campus Drive, 1st Floor North,
Parsippany, NJ 07054-3802

Phone: 973/267-9700 | FAX: 973/267-9055
Web Site: www.pumps.org

IEEE – INSTITUTE OF ELECTRICAL & ELECTRONICS ENGINEERS, INC.

445 Hoes Lane P.O. Box 1752, Piscataway, NJ 08855-1331
Phone: 800/678-IEEE (4333) | FAX: 732/981-9667
Web Site: www.ieee.org

MSS – MANUFACTURING STANDARDIZATION SOCIETY

127 Park Ave., NE, Vienna, VA 22180
Phone: 703/281-6613 | FAX : 703/281-6671
Web Site: www.mss-hq.org

NEMA – NATIONAL ELECTRICAL MANUFACTURERS ASSOCIATION

1300 North 17th Street, Suite 184, Rosslyn, VA 22209
Phone: 703/841-3200 | FAX: 703/841-5900
Web Site: www.nema.org

NEC – NATIONAL ELECTRICAL CODE

PUBLISHED BY NFPA – NATIONAL FIRE PROTECTION ASSOCIATION (NFPA)

P. O. Box 9101, 1 Batterymarch Park
Quincy, MA 02269-9101

Phone: 617/770-3000 | FAX: 617/770-0700
Web Site: www.nfpa.org

NSF INTERNATIONAL

P. O. Box 130140, NSF Building

789 N. Dixboro, Ann Arbor, MI 48105

Phone: 734/769-8010 | FAX: 734/769-0109
Web Site: www.nfs.org

UL – UNDERWRITERS LABORATORIES

333 Pfingsten Road, Northbrook, IL 60062

Phone: 847/272-8800 | FAX: 847/272-8129

Web Site: www.ul.com

Conformance to applicable UL Standards is required in the U. S. for virtually all installation.

SWPA's Technical Resources

THERE ARE A NUMBER OF TECHNICAL RESOURCES AND INFORMATIONAL ITEMS YOU CAN USE TO LEARN MORE ABOUT SUBMERSIBLE WASTEWATER PUMPS AND THE SUBMERSIBLE WASTEWATER PUMP INDUSTRY; OBTAIN ESSENTIAL INFORMATION FOR SPECIFYING SUBMERSIBLE WASTEWATER PUMPS, AND ASSIST YOU WITH THE DESIGN, INSTALLATION, AND PROPER OPERATION OF SUBMERSIBLE WASTEWATER PUMPING SYSTEMS AND GRINDER PUMP STATIONS. THE MOST SIGNIFICANT OF THESE RESOURCES ARE PUBLISHED BY SWPA AND ARE DESCRIBED ON THE FOLLOWING PAGES.

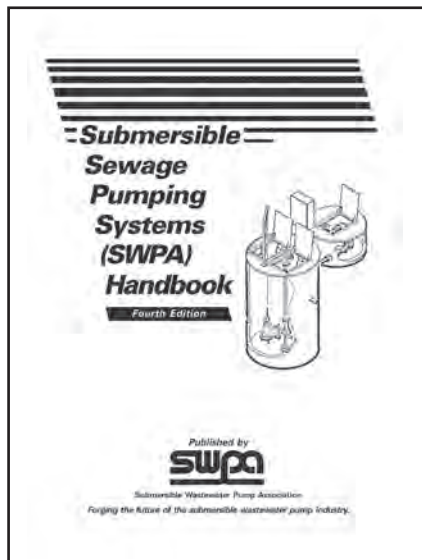

THE "BIBLE" OF THE INDUSTRY SINCE 1984...THERE'S NO BETTER REFERENCE TOOL.

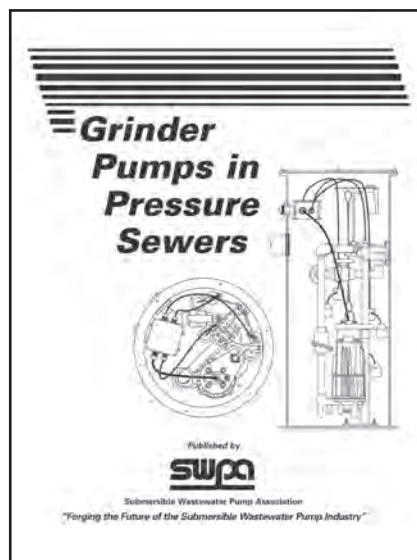

A MUST FOR UNDERSTANDING AND USING PRESSURE SEWER TECHNOLOGY.

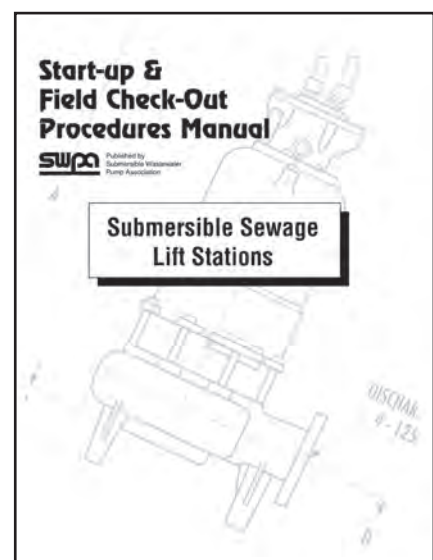

A DISTINCTIVE "HOW TO" GUIDE WITH EXPLANATIONS FOR PERSONNEL IN THE FIELD.

SWPA's CURRENT TECHNICAL RESOURCES

For ordering information, see page 31.

SWPA'S TECHNICAL RESOURCES, described below, are based on "The Systems Approach" to the Design, Construction, Maintenance and Operation of Lift Stations and Grinder Pump Stations.

SUBMERSIBLE SEWAGE PUMPING SYSTEMS (SWPA) HANDBOOK – 4TH EDITION

THE *SWPA HANDBOOK* is a landmark publication. It presents fundamentals and addresses some of the more sophisticated aspects of submersible wastewater pump systems and their components. This unique publication presents more than 80 tables, charts, diagrams, photographs, and other visuals to greatly enhance its value.

A Glossary of System Terms and a Glossary of Electrical Terms are included.

Also included is a variety of resource materials, including friction loss tables for various pipe and fitting configurations and *SWPA's Standardized Presentation Format for Pump and Motor Characteristics* – an evaluation tool that presents the minimum data needed to evaluate using a specific pump for a specific application is also included.

SWPA Handbook is intended to familiarize and assist those responsible for designing, installing, and operating lift stations using submersible solids-handling pumping systems. It emphasizes the design, installation, and operation of a system of carefully integrated components.

Here are descriptions of The Chapters, Glossaries, and Appendixes

Fundamentals and Components – Wet wells. Types and sizes of stations. Site selection considerations.

Sizing the System – Planning the sewage system. How to size the lift station.

Selection of Submersible Pumps – Submersible system components. Factors in selecting the right pump.

Grinder Pumps and Pressure Sewers – Applications. Advantages. Design criteria. Equipment. Construction. Operation and Maintenance.

Controls for Submersible Pumps – Power Supply; Voltages and Phases available and Why?; Standby Power Sources; Motor Controllers; Level Control Systems; Hazardous Area Applications; Operation Sequences, Auxiliary Equipment; Auxiliary Equipment; and Grinder Pump Controls.

Variable Speed Pumping – Basic information. Considerations and design guidelines about variable speed pumping and variable frequency drives. Descriptions of each contributing component of the variable speed pumping system, how it interacts with other components. Advantages and disadvantages of applying such a design to submersible pumping equipment.

Dry Pit Submersible Pumps – General Description; Advantages; Applications; Pump Station Design; Pump Mounting Arrangements; and Electrical Design.

Mechanical Controls and Components – Valve types and uses. Selecting access covers.

Installation and Start-Up – Preparatory steps. Equipment. Start-up, including pump and control system testing.

Operation and Maintenance – Procedures for periodic maintenance and troubleshooting.

Glossaries – System and electrical terms.

Appendixes – Pump and electrical system references, including friction loss tables.

GRINDER PUMPS IN PRESSURE SEWERS

SINCE THE EARLY 1970s, pressure sewer systems have been an effective method to move residential wastewater through the small diameter pipes of a wastewater collection system where other methods

are less economical and less feasible.

This SWPA Technical Resource is a must for understanding and using pressure sewer technology. It describes the use of pressure sewer technology to solve challenging wastewater disposal requirements where other methods may be less economically feasible or environmentally acceptable.

Extremely low operating and maintenance (O&M) costs have been documented. Data is now available from a plethora of successful systems -- some in operation since the early 1970s. By taking advantage of the experience which these systems offer, a new system can be planned which will provide excellent performance, high reliability, and reasonable O&M costs.

It describes:

- The keys to understanding the differences between conventional gravity sewer systems and pressure sewer systems, the piping network and the reduction of solids size in the wastewater. Pressure sewer systems use grinder pumps to reduce the solids present to particles, which can easily be moved through small diameter pipes.
- The use of pressure sewer system technology to solve challenging sewage disposal requirements where other methods may be less economically feasible or environmentally acceptable.
- How the application of grinder pumps and pressure sewer systems is a cost-effective, permanent answer to allow more sites, existing and new, to have access to a public sewer system.

Pressure sewer systems using grinder pumps are particularly useful in new construction of subdivisions and second home communities and in existing communities with aging septic tanks.

The problems of aging septic tanks and unsatisfactory soil conditions and an increased emphasis on environmental issues can be economically solved with pressure sewers. Pressure sewers are compatible with other collection system techniques.

.....The advantages of each technology can be blended into site-specific designs using grinder pumps, gravity systems, large submersible pumping stations, and force mains. There is virtually no limit to the type of discharge point to which a pressure sewer using grinder pumps can be connected.

Grinder Pumps in Pressure Sewers features numerous photographs, charts, graphs and other visuals as well as sections on:

- A General Description of Grinder Pumps in Pressure Sewers
- Advantages To Using Pressure Sewer Systems
- System Design Criteria
- Equipment Requirements
- Up Front Planning
- Installation and Start-Up
- Operations and Maintenance

IN ITS APPENDIX, *Grinder Pumps in Pressure Sewers* includes a Pressure Sewer Systems Glossary; Grinder Pump definitions, Drawings and Common Terminology; a Basin Installation Reference Guide, and an extensive Bibliography of additional sources of information about these products.

START-UP AND FIELD CHECK-OUT PROCEDURES MANUAL FOR SUBMERSIBLE SEWAGE LIFT STATIONS

This practical, 28-page Manual includes procedures for flow and performance evaluation based on equipment available.

Based on field research, SWPA's Technical Committee determined that a "how to" training guide with an explanation of "here's why you're doing it" for use when starting up a submersible sewage lift station was needed for personnel in the field. This Manual was developed in response to that need.

SWPA's *Start-Up and Field Check-Out Procedures Manual for Submersible Sewage Lift Stations* describes different levels of procedures, based on equipment typically available to start-up personnel in the field, to be used in conjunction with the pump manufacturers start-up and check-out document and *Pump Instruction and Operation Manual – not in place of it*.

It presents step-by-step procedures to put a lift station into service and lists start-up and check-out procedures at three separate levels, based on equipment available. These are:

- Using a Multimeter.
- Using a Multimeter and a Clamp-On Ammeter.
- Using a Voltmeter, a Clamp-On Ammeter, and a Megommeter.

It also presents:

- Procedures for flow and performance evaluations were also developed based on equipment available. *These procedures are:*
- Flow Evaluation Using a Watch Displaying Seconds
- Performance (Flow and Head) Evaluation Using a

Watch Displaying Seconds and a Pressure Gauge

In addition to the step-by-step procedures to put a lift station into service, the Manual also includes:

- A listing of periodic station checks and inspections;
- Notes on operation and maintenance,
- A sample Start-Up Report Form,
- A drawing showing a typical submersible pump station.
- SWPA's *Common Terminology for the Components of a Typical Submersible Pump Station*;
- Glossaries of System and Electrical Terms.
- A listing of selected standards setting organizations.

■ ALSO AVAILABLE ■

A CD-ROM WITH BOTH THE SUBMERSIBLE SEWAGE PUMPING SYSTEMS (SWPA) HANDBOOK FOURTH EDITION AND THE START-UP AND FIELD CHECK-OUT PROCEDURES MANUAL FOR SUBMERSIBLE SEWAGE LIFT STATIONS

THE VERY VERSATILE SUBMERSIBLE – This SWPA Training Video discusses some of the ways this proven machine serves pump specifiers and users throughout the world. It is...

- An eight-minute presentation that describes the versatile submersible as "a finely tuned machine designed to operate within the liquid being pumped. It moves suspended solids as well as liquids. The submersible takes little space...operates at a high hydraulic efficiency ...and is easily maintained and serviced."
- A video training tool aimed at informing the viewer of the advantages and multiple uses of submersible wastewater pumping equipment.

Distributors, contractors, specifiers, users, wastewater facilities managers, regulatory agencies, standards setting organizations, classes at engineering schools, and others interested in learning more about submersible wastewater pumps for municipal and industrial applications can use "The Very Versatile Submersible" to provide sound background information or as a discussion starter.

STANDARDIZED PRESENTATION FORMAT FOR PUMP AND MOTOR CHARACTERISTICS* – SWPA has developed a *Standardized Presentation Format for Pump and Motor Characteristics* for a pump or family of pumps.

The required information included in the presentation format is the minimum data needed by a specifier or designer to adequately evaluate using a specific submersible wastewater pump for a specific application.

SWPA MEMBERS MAY USE the Association's Logo with the designation "***Approved Curve and Data Format***" in conjunction with statements that their performance curve(s) provide a minimum number of data categories and the minimum design information as recommended by the Association. Pump manufacturers, at their discretion, may include additional information. SWPA assumes no responsibility for any other manufacturer claims made relating to the pump performance curve(s) or for the correctness of the information presented.

The following statement is to be included on any performance curve(s) carrying the SWPA Member Logo. "*SWPA Data Categories Presented – Data on this sheet supply design information as the minimum recommended by the Submersible Wastewater Pump Association (SWPA) and is defined in accordance with SWPA's Standardized Definitions for Pump and Motor Characteristics. The accuracy of the data is the responsibility of (company name).*"

At the pump manufacturer's choice, the presentation may be in a one-page or two-page format, including a performance curve(s) and the minimum pump and motor data design as recommended by SWPA.

Each company seeking approval to use the "***Approved Curve and Data Format***" logo, is required to file a formal application which includes a *Statement of Compliance*, attesting that the company's Chief Engineer or Technical Manager: "Has reviewed our performance curve(s) and appropriate minimum data as prescribed by SWPA and to the best of our ability and knowledge all sheets for which we are seeking approval to display the SWPA Member Logo are in compliance with the SWPA recommendations for minimum data to be included and that the data is presented as defined by *SWPA's Standardized Pump/Motor Definitions*."

Each application and accompanying curve and data presentation is reviewed by the Association's Technical Committee to insure that the minimum recommended data and information are included.

Those that meet the minimum requirements are then permitted to use the logo and accompanying

language, indicating conformance with the SWPA *Standardized Presentation Format*.

BY USING THE SWPA Standardized Presentation Format, pump manufacturers present data in a consistent arrangement so the designer or specifier can make an informed comparison between different brands or types of equipment. A major component of the presentation format is a series of *Standardized Pump/Motor Definitions* developed by the Association. They define the terms that the data represent. (*Motor characteristics terms are as defined by NEMA motors and generators No. MGI-1978, NEC-1990, IEEE Std. 100-1992.*)

COMMON INDUSTRY TERMINOLOGY – As part of its Common Terminology Project, SWPA has developed a "Master List" of System and Electrical definitions and a series of drawings with call-outs and accompanying nomenclature related to submersible wastewater pumps, submersible wastewater pump stations, and grinder pump stations:

- **SYSTEM TERMS AND DEFINITIONS^{1*}**
- **ELECTRICAL TERMS AND DEFINITIONS^{1*}**
- **COMMON TERMINOLOGY AND DEFINITIONS OF A TYPICAL SUBMERSIBLE LIFT STATION^{1*}**
- **COMMON TERMINOLOGY AND DEFINITIONS FOR A TYPICAL GRINDER PUMP STATION¹**

PRESS INFORMATION KIT ABOUT GRINDER PUMPS IN PRESSURE SEWERS* – SWPA'S Press Information Kit On Grinder Pumps in Pressure Sewer Systems includes a white paper entitled "A Pressure Sewer Overview – A Proven Approach to Moving Wastewater from One Point to Another", a series of Frequently Asked Questions (FAQ's) and answers about grinder pumps and pressure sewers, and a compilation of Grinder Pump Definitions, Drawings, and Common Terminology.

Grinder pumps are used to power small diameter pressurized sewer systems in areas where gravity piping is uneconomical or impractical. Grinder systems work especially well in hilly or rocky terrain. They sharply reduce construction and equipment costs.

In fact, grinder pumps make it possible to serve many developments and communities in terrain where service was previously impractical.

THE WHITE PAPER'S EXECUTIVE SUMMARY begins by saying: "For many years, pressure sewer systems have been an effective method to move residential wastewater through small diameter pipes to collec-

tion facilities where other methods are less economical or less feasible.”

The keys to understanding the differences between conventional gravity sewer systems and pressure sewer systems are the piping network and the reduction of solids size in the wastewater.

THERE ARE 21 FAQs (and answers) that include definitions, cost and power explanations, system descriptions, life expectancy and other topics of interest to engineers, builders, developers and homeowners. The definitions and drawings establish a common terminology for centrifugal and progressing cavity style grinder pumps.

AN INTRODUCTION TO GRINDER PUMPS IN PRESSURE SEWERS* (NEW) – A generic Training Presentation designed to be used as an introduction to pressure sewer systems to educate engineers, builders, developers, homeowners, young consulting engineers inexperienced in grinder pump systems and system design, industry groups without knowledge of grinder pump systems and others.

SUBMERSIBLE WASTEWATER PUMPING SYSTEMS USERS AND SPECIFIERS GUIDE – A submersible wastewater lift station *Users' and Specifiers Guide* to SWPA's manufacturer members and the products they produce and sell and our Associate Members and the services they provide. It includes basic industry information as well as general information about the Association and its programs and services. It includes member company listings by category

– Pump Manufacturers, Component Manufacturers, and Associate Members. Each member company listing includes the company's main address, phone number, fax number, Web Site, Product and Service Codes, as well as sales and technical contact information for each company with phone numbers and e-mail addresses.

THE SWPA Membership Roster and Product Reference Guide also includes advertising from member companies, information about the current and planned Technical Resources published by the Association, and our unique educational and training programs – all based on “*The Systems Approach*.”

Additional copies are available upon request from SWPA Headquarters or on www.swpa.org.

** These items are downloadable from the SWPA Web Site at www.swpa.org*

1. SWPA recognizes and acknowledges that there is other appropriate nomenclature for many of these terms and terminology. However, to coordinate and insure the consistency of terms, terminology and definitions within all SWPA publications as well as between SWPA publications and accepted Industry Standards and guidelines, the Association uses terms, terminology, and definitions from this “Master List”.

SWPA TECHNICAL RESOURCES UNDER DEVELOPMENT

TO EXPAND its publishing efforts to meet the current, ongoing, and future needs of the industry it serves, and in accordance with its strategic initiatives, SWPA is developing new Technical Resources based on “*The Systems Approach*.”

Submersible wastewater pump stations contain a number of complex interdependent components that must be properly matched to each other to ensure long, satisfactory and economic life.

BECAUSE OF THIS NEED, when in print each of these publications will present fundamentals with an emphasis on the design, construction, installation, operation and maintenance of a *system* of carefully integrated components. Using this approach will assist consulting engineers, specifiers, users, and others gain a better understanding of the interaction between the pump, valves, control panels, VFDs, basins, mechanical seal materials and other com-

ponents and how they interact to produce a *system* to create optimum performance, minimum maintenance, and long life.

Visit the SWPA Web Site at www.swpa.org for information and special pre-publication offers on these Technical Resources as they near publication.

SUBMERSIBLE SEWAGE PUMPING SYSTEMS (SWPA) HANDBOOK 4TH EDITION – with over 30,000 copies sold world wide, the 4th Edition of “The Industry Bible” was released in the fourth quarter of 2012. It includes a new chapter on Motors, expanded information on the Fundamentals & Components to “The Systems Approach,” updated information on Selection of Submersible Pumps, a completely new chapter on Grinder Pumps in Pressure Sewers, updated charts, tables and more. Look for a version in Spanish coming soon. An e-book version is also available at the Association’s website, www.swpa.org.

SUBMERSIBLE SEWAGE PUMPING SYSTEMS (SWPA) HANDBOOK – CONDENSED EDITION – A tutorial/guideline, based on the *Submersible Sewage Pumping Systems (SWPA) Handbook, 4th Edition* that will serve as an introduction to the design and proper application of submersible wastewater pumps and the many inter-dependent components and accessories that are used in solids-handling lift stations and grinder pump stations. It promotes an increased understanding of submersible pump design and the proper application of these products.

SYSTEM COMPONENT GUIDELINES (*separate publications on major components in a wastewater pumping system*) – SWPA initiatives also call for creating a series of publications based on the Association’s established product codes and “*The Systems Approach*,” that will be performance based tutorials/guidelines for designing, installing, operating, and maintaining the major components in a submersible wastewater pumping system. These publications will provide descriptive information on the components in the system and how those components interact with, impact upon, and affect each other, including equipment guidelines, in a standardized format. Each publication in the series will utilize components of the SWPA Common Terminology Project.

These publications will be tutorial/ guidelines, providing the reader with specific information about “*What you need to know when specifying, designing, constructing, operation and maintaining*” the inter-dependent components in a submersible wastewater systems.

They will present fundamentals with an emphasis on the design, construction, installation, operation, and maintenance of a *system* of carefully integrated components and will contain technical and specialized information intended to be used by professionals who design, install, operate, and maintain submersible wastewater pump stations; qualified design engineers, professional installers; and others.

SUBMERSIBLE WASTEWATER PUMPING SYSTEMS MANUAL (*Engineering, Applications and Component Integration for Use in Submersible Wastewater Pump Stations*) – This upcoming SWPA Technical Resource will be a comprehensive manual covering all aspects of a submersible wastewater pumping system, including the entire design, operation, and maintenance of a lift station and will be based on “*The Systems Approach*.”... and a compilation of SWPA’s Technical Resources – including reference materials, guidelines, tutorials, training materials, and other informational items.

NOTES ON OPERATION AND MAINTENANCE

Regular inspection and preventive maintenance will insure continued, reliable operation of the entire submersible pump station. All stations, pumps, and operating equipment should be inspected at least once a year, and more frequently under severe operating conditions. All equipment in the station should be backed by manufacturers’ service manuals. This material should be carefully read and filed and should be consulted whenever servicing is required.

In conducting regular inspections and preventative maintenance, be sure to follow the manufacturer's recommendations (pump, control panels, valves, etc.).

Note and read all safety precautions before performing any operation or maintenance procedure and take appropriate safety precautions to minimize the risk of accidents in connection with any service work.

Before starting work, make sure the pump and the control panel are isolated from the power supply and that neither can be energized.

*Like all products using electrical current, submersible wastewater pumps can result in harm if not used with **extreme caution** and in strict accordance with the manufacturer’s instructions and in accordance with local building codes and ordinances.*

For additional information on Operation and Maintenance, including: A “Trouble Checklist” of common problems and their probable causes, Safety Precautions and Recommended Inspections consult *Submersible Sewage Pumping Systems (SWPA) Handbook – 4th Edition*.

SWPA TECHNICAL RESOURCES ORDER FORM

(YOU MAY ALSO ORDER ONLINE @ WWW.SWPA.ORG)

DISCOUNTS ARE AVAILABLE FOR NON-MEMBER ORDERS OF 25 OR MORE COPIES AND TO EDUCATIONAL INSTITUTIONS FOR ANY SWPA TECHNICAL RESOURCE. FOR INFORMATION ON THESE DISCOUNTED PRICES, CONTACT SWPA HEADQUARTERS.

RETURN THIS COMPLETED ORDER FORM, ALONG WITH YOUR CHECK OR CREDIT CARD INFORMATION TO:

SUBMERSIBLE WASTEWATER PUMP ASSOCIATION

350 NORTH LASALLE STREET, 9TH FLOOR • CHICAGO, IL 60654

FOR INFORMATION, CALL (847.681.1868) • FAX (312.475.9022) OR E-MAIL (SWPAEXDIR@SBCGLOBAL.NET)

PAYMENT IN U. S. FUNDS MUST ACCOMPANY THIS ORDER. ALLOW 4-6 WEEKS FOR DELIVERY.

Send me _____ copy (ies) of the ***Submersible Sewage Pumping Systems (SWPA) Handbook Fourth Edition*** @ \$36.95 per copy plus \$5.00 shipping and handling per copy for U.S. Shipments (\$7.00 per copy for Canadian shipments.*)

Send me _____ copy (ies) of the ***Grinder Pumps in Pressure Sewers*** @ \$10.95 per copy plus \$4.00 shipping and handling per copy for U.S. Shipments (\$6.00 per copy for Canadian shipments.*)

Send me _____ copy (ies) of the ***Start-Up and Field Check-Out Procedures Manual for Submersible Sewage Lift Stations*** @ \$5.00 per copy plus \$3.00 shipping and handling per copy for U.S. Shipments (\$4.50 per copy for Canadian shipments.*)

Send me _____ copy (ies) of the CD-ROM with the ***Submersible Sewage Pumping Systems (SWPA) Handbook Fourth Edition*** and the ***Start-Up and Field Check-Out Procedures Manual for Submersible Sewage Lift Stations*** @ \$34.95* per copy plus \$6.50 shipping and handling per copy for U.S. Shipments (\$8.50 per copy for Canadian shipments.*)

Send me _____ copy (ies) of ***The Very Versatile Submersible Video CD*** @ \$5.00 per copy plus \$3.00* shipping and handling per copy for U.S. Shipments. (\$4.50 per copy for Canadian shipments.*)

Send me _____ special package(s) consisting of one copy each of the ***Submersible Sewage Pumping Systems (SWPA) Handbook Fourth Edition, Start-Up and Field Check-Out Procedures Manual for Submersible Sewage Lift Stations and The Very Versatile Submersible Video CD*** @ \$42.95 plus \$8.50 shipping and handling per package (\$10.00 per package for Canadian shipments.*)

** Contact SWPA Headquarters for S&H costs to other destinations. Standard shipments are sent via USPS. Overnight and 2nd Day Air shipping available at an additional charge. Contact SWPA headquarters for details.*

Incomplete or incorrect information can delay shipments.

My check for \$ _____ is enclosed.

Name _____

Company _____

Street Address (No P.O. Boxes, Please) _____

City _____ State _____ ZIP _____

Phone (AC ____) _____

E-mail _____ Date _____

For Credit Card Purchases:

Charge my credit card \$ _____

Type of Card: Visa Mastercard AMEX Discover

Name on Card _____

Address on Card Account _____

City _____ State _____ ZIP _____

Account # _____

Exp. Date _____

To better serve you, please check the appropriate box(es) describing your company:

Consulting Engineer

Service Shop

Component Manufacturer

Other (Please Specify): _____

Distributor

Systems Packager

User

Rep Organization

Pump Manufacturer

Educational Institution

PUMP MANUFACTURER MEMBERS

SWPA's PUMP MANUFACTURER MEMBERS ARE MANUFACTURERS OF SUBMERSIBLE WASTEWATER PUMPS FOR MUNICIPAL AND INDUSTRIAL APPLICATIONS THAT CAN EFFICIENTLY HANDLE SOLIDS.

CRANE PUMPS & SYSTEMS

420 Third Street, Piqua, OH 45356

Phone: 937/214-5325 ■ FAX: 937/773-9715

Web Site: www.cranepumps.com

Products: CP, DP, GP, IP, SH, TP, OP (Sewage Injector and Effluent Pumps), AC, AT, BS, CC, CP, CT, EM, GR, LA, PC, PM, PS, PB, SE, SS, VA, VFD, WW, OO (Liquid Level Controls)

Technical Contact: Chuck Drake, Product Manager Submersible Pumps. 937/615-3578 cdrake@cranepumps.com

Sales Contact: Walt Erndt, VP/GM 937/778-3504. FAX: 937/778-5969. werndt@cranepumps.com

EBARA

1651 Cedar Line Drive, Rock Hill, SC 29730

Phone: 803 327-5005 ■ FAX: 803 327-5097

Web Site: www.pumpsebara.com

Products: CP, DP, GP, IP, SH, OP

Sales/Technical Contact: Customer Service 803/327-5005. customer_service@pumpsebara.com

ENVIRONMENT ONE CORPORATION

2773 Balltown Road, Niskayuna, NY 12309

Phone: 518/346-6161 ■ FAX: 518/346-6188

Web Site: www.eone.com/sewer

Products: GP, CT

Sales Contact: Chris Greco, Director of Sales cgreco@eone.com

Technical Contact: Clark Henry, VP of Engineering. chenry@eone.com

FRANKLIN ELECTRIC (LITTLE GIANT)

9255 Coverdale Rd., Fort Wayne, IN 46809

Phone: 888-885-8989 ■ FAX: 260-827-5654

Web Site: www.franklinengineered.com / www.littlegiant.com

Products: CP, GP, IP, SH, AC, AT, BS, CC, CP, CT, GR, LA, PC, PM, PB, SE, SS, VA, VFD

Sales Contact: Twain Glaser, 717/504-2625. tglaser@fele.com

Technical Contact: Jessie Hinthner, 405/440-1390. jhinther@fele.com

Technical Contact Little Giant: Randy Tucker, 405/440-1347. rtucker@fele.com

THE GORMAN RUPP Co.

600 S. Airport Rd., Mansfield, OH 44903

Phone: 419/755-1011 ■ FAX: 419/755-1251

Web Site: www.grpumps.com

Products: DP, IP, SH, OP (self-priming centrifugal, rotary gear), CP, CT, LA

Sales Contact: Vince Baldasare, Sales Manager, Engineered Systems. 419/755-1271.

FAX: 419/755.1208. vbaldasare@gormanrupp.com

Technical Contact: Vince Baldasare

GOULDS WATER TECHNOLOGY A XYLEM BRAND

2811 East Bayard Street, Suite A

Seneca Falls, NY 13148

Phone: 315/239-2980 ■ FAX: 315/568-7644

Web Site: www.completewatersystems.com

Products: CP, GP, IP, SH, TP, AC, AT, BS, CC, CP, CT, EM, GR, LA, PS, PB, SE, SS, VA, VFD, WW

Sales Contact: William Gell, Product Manager, Wastewater. 315/239-7004.

william.gell@xylem.com

Technical Contact: Joe Steinberg, Asst. Product Manager, Wastewater 315/239-2419.

joe.steinberg@xylem.com

GRUNDFOS/WATER UTILITY

3905 Enterprise Court

Aurora, IL 60504

Phone: 630/236-5500 ■ FAX: 630/236-5511

Web Site: www.grundfos.com

Products: CP, DP, IP, SH, AC, BS, CC, CP, CT, EM, GR, LA, PM, PB, WW

Sales Contact: Rob Montengro, Vice President Sales. rmontengro@grundfos.com

Technical Contact: Russell Smith, Business Development Manager, Wastewater. 224/500-6388 rusmith@grundfos.com

HOMA PUMP TECHNOLOGY

Fountain Lake Commerce Park, 390 Birmingham Blvd., Ansonia, CT 06401

Phone: 203/736-8890 ■ FAX: 203/736-8899

Web Site: www.homapump.com

Products: CP, DP, GP, SH, OP (Choppers), AC, BS, CC, CP, CT, EM, GR, LA, PB, SE, SS, VA

Sales Contact: John Lord, Business Development Manager. JLord@homapump.com

Technical Contact: Ryan Sura, Senior Application Engineer. RSura@homapump.com

KSB, INC.

4415 Sarellen Road, Richmond, VA 23231

Phone: 804/222-1818 ■ FAX: 804/226-6961

Web Site: www.ksbusa.com

Products: AP, CP, DP, GP, IP, SH, TP, O (Mixed Flow Submersible)

Sales Contact: Sherry Heinly, Marketing Manager, Ext. 8353. Sheinly@ksbusa.com

Technical Contacts: Dr. T. Ravisundar, Vice President Technical Services.

travisundar@ksbusa.com.

Steve Lundgren, Vice President of Sales.

slindgren@ksbusa.com

MODY PUMPS, INC.

2166 Zeus Ct., Bakersfield, CA 93308

Phone: 661/392-7600 ■ FAX: 661/392-7601

Web Site: www.modypump.com

Sales Contact: Barbara Taire, Inside Sales. 661/392-7600. FAX: 661/392-7601

Barbara@modypump.com

Technical Contact: Paul Aguilar, Service and Operations Manager. 661/392-7600.

FAX: 661/392-7601 paul@modypump.com

PENTAIR

5500 Wayzata Blvd., Minneapolis, MN 55416-1261

Phone: 763/545-1730 ■ FAX: 763/656-5400

Web Site: www.pentair.com

Products: AP, AC, BS, CP, DP, GP, IP, SH, TP, OP, CC, CT, EM, GR, LA, PC, PM, PB, SE, SS, VA, VFD, VW

Sales Contact: Joe Jackson, Vice President of Sales. 913/748-4202. FAX: 913/748-4025

Joe.Jackson@pentair.com

Technical Contact: Barry Jongsma, Manager, Product Engineering. 913/748-4153.

FAX: 913/371-6969 Barry.Jongsma@pentair.com

Nicole Osborne, Product Marketing Manager. 419/281-9225. Fax: 888/207-0597.

Nicole.Osborne@pentair.com

SULZER PUMP SOLUTIONS (US), INC.

140 Pond View Drive, Meriden, CT 06450

Phone: 203/238-7000 ■ FAX: 203/238-0738

Web Site: www.sulzer.com

Products: AP, CP, DP, GP, IP, SH, AC, BS, CP, CT, GR, LA, PC, PM, PB, SE, SS

Sales Contacts: John Everhart, Reg. Head Sales Americas. 203/238-2700. FAX: 203/238-0738.

john@sulzer.com

WEIL PUMP COMPANY INC.

W57 N14363 Doerr Way, P.O. Box 887, Cedarburg, WI 53012

Phone: 262/377-1399 ■ FAX: 262/377-0515

Web Site: www.weilpump.com

Products: AP, CP, DP, GP, IP, SH, AC, AT, BS, CC, CP, CT, EM, GR, LA, PM, SE, SS, VA, VFD, WW

Sales Contact: Tim Bade, Sales

tbade@weilpump.com

Technical Contact: Jeff Plaster, Applications Engineer. dplaster@weilpump.com

XYLEM FLYGT PRODUCTS**14124 South Bridge Circle, Charlotte, NC 28273****Phone: 704/409-9750 ■ FAX: 704/409-9800**Web Site: <http://www.flygt.com/en-us> or www.xyleminc.com/us*Products:* AP, CP, DP, GP, IP, SH, TP, OP
(Choppers) AC, BS, CC, CP, CT, GR, LA, PM, PB,
SS, VA, VFD, WW*Sales Contacts:* Lisa Riles, Business Development
Manager, Wastewater Pumps.

lisa.riles@xyleminc.com

Bob Domkowski, Engineering Consultant.

bob.domkowski@xyleminc.com

ZOELLER ENGINEERED PRODUCTS**3649 Cane Run Road, Louisville, KY 40211-1961****Phone: 800/928-7867 ■ FAX: 502/774-3624**Web Site: www.zoeller.com*Products:* CP, DP, GP, SH, AC, AT, BS, CT, GR, LA,
PB, PS, SS, VA, WW*Sales Contact:* Steve Doolittle, Product Line
Manager. Ext. 8215. steved@zoeller.com*Technical Contact:* Andrew Ulliman, Product
Engineer. Ext. 8130. andrewu@zoeller.com**PERIODIC STATION CHECKS AND INSPECTIONS**

Weekly station checks should be performed and data recorded in the Station Log Book. Certain visual inspections should be made, amperage readings should be taken and recorded, and megohmmeter checks should be made.

It is recommended that a *Station Log Book* be created to record and maintain this data, based on the needs and specifics of the individual station. There is no universally accepted format for a Station Log Book and no pre-formatted forms for recording station data. *Whatever format is used, it is recommended that the Station Log Book be kept at the station in the control panel.*

A daily planner type book, available in most office supply stores, offers an ideal format for a *Station Log Book*. For most stations, a standard, wirebound book, 4-7/8" x 8" page size, dated for a full year, with one weekday per page, Saturday and Sunday combined, is sufficient.

This format and size is ideal to use for recording station information and maintaining a record of periodic maintenance done on the station.

The lined format allows space for comments about the station's operation which need to be noted. This might not be easily accomplished on a pre-formatted form. The value of the *Station Log* is in consistently utilizing the book and noting all important information so it can be used for analysis and comparison.

TYPICAL SUBMERSIBLE PUMP STATION

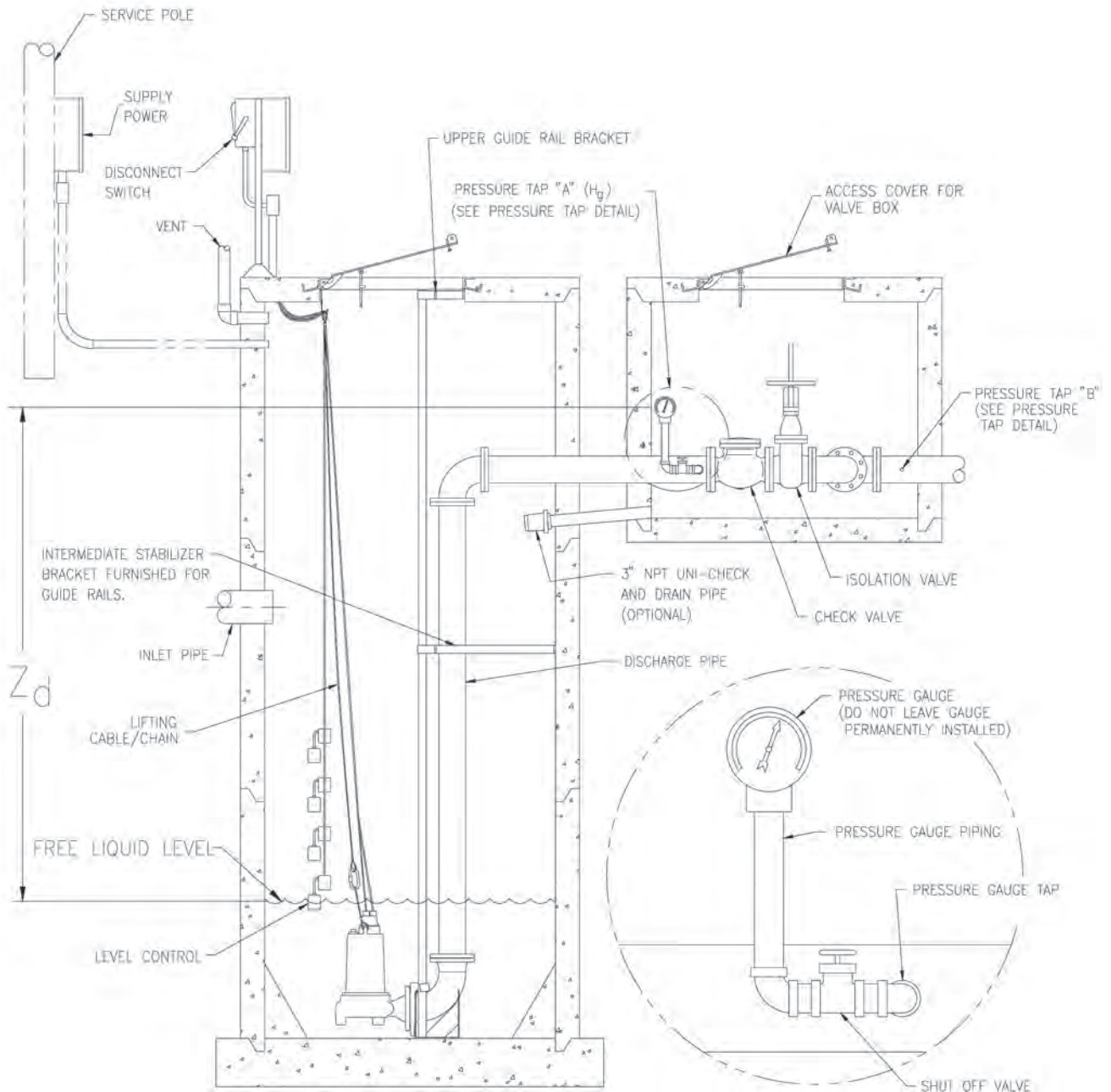

PRESSURE TAP DETAIL

COMPONENT MANUFACTURER MEMBERS

COMPONENT MANUFACTURER MEMBERS ARE MANUFACTURERS OF COMPONENT PARTS AND ACCESSORY ITEMS FOR SUBMERSIBLE WASTEWATER PUMPS AND SYSTEMS UTILIZING SUCH PUMPS.

FLOMATIC CORPORATION

15 Pruyn's Island Drive, Glens Falls, NY 12801

Phone: 518/761-9797 ■ FAX: 518/761-9798

Web Site: www.flomatic.com

Products: VA

Sales Contact: Nick Farrara, Vice President of Sales.
518/832-6767. FAX: 518/761-9798.

nick@flomatic.com

Technical Contact: Brian Allen, Design Engineer.
518/761-9797 EXT 238. FAX: 518/761-9798

allen@flomatic.com

MOTOR PROTECTION ELECTRONICS (MPE)

2464 Vulcan Road, Apopka, FL 32703

Phone: 407/299-3825 ■ FAX: 407/294-9435

Web Site: www.mpeelectronics.com

Products: AT, CP, LA, PM

Sales Contact: John Evans, President

john_evans@mpeelectronics.com

Technical Contact: Chris Parker, Engineering

chris_parker@mpeelectronics.com

OHIO ELECTRICAL CONTROL, INC. 2395

Rock Rd., Ashland, OH 44805

Phone: 419/289-1553 ■ FAX: 419/289-5555

Web Site: www.oecinc.net

Products: AT, CP, CT, LA, PC, PM, SS, VFD, OO

Sales Contact: Jennay Cacchio, Operations Manager.

419/289-1553. jennay@oecinc.net

Technical Contact: Dave Baker, Engineering

Supervisor. 419/289-1553. dave@oecinc.net

Sales: Leslie Blankenship, Manufacturing Manager.

leslie@oecinc.net

SJE RHOMBUS

22650 County Highway 6, P.O. Box 1708

Detroit Lakes, MN 56502

Phone: 888/434-5753 ■ FAX: 218/847-4617

Web Site: www.sjerhombus.com

Products: AT, CP, CT, LA, PC, PM, SS, VFD

Sales & Technical Support: Loran Knudsvig, Sales

Director, Standard Products. Cell: 218/850-0961.

Office: 218/847-1317 Ext. 3404.

Loran.Knudsvig@sjerhombus.com

ROCKWELL AUTOMATION, INC.

1201 South Second St., Milwaukee, WI 53204

Phone: 414/382-2000

Web Site: www.rockwellautomation.com/industries/water

Products: CP, CT, VFD

Sales Contact: Christa Bankay, Commercial Project
Manager. 519/244-5320. cdbankay@ra.rockwell.com

Technical Contact: Kelvin Hurdle, Manager,
Business Development. 602/697-7372

kjhurdle@ra.rockwell.com

SCHNEIDER ELECTRIC (SQUARE D/ BY SCHNEIDER ELECTRIC)

8001 Knightdale Blvd., Knightdale, NC 27545

Phone: 919/217-6464 ■ FAX: 919/266-4460

Web Site: www.schneider-electric.com

Products: CP, CT, PC, PM, VFD, OO (soft starters, motor starters, circuit breakers, disconnects, programmable logic controllers, sensors and other electrical and electronic devices used in conjunction with the submersible pump industry).

Sales Contact: Jack Creamer, Segment Manager-
Pumping Equipment, Pumping Equipment. 919/217-
6464 or jack.creamer@schneider-electric.com

Technical Contacts: Siva Kanesvaran, Application
Development Engineer. 919/266-8605 or
siva.kanesvaran@schneider-electric.com.

Chris Thomas, Application Development Engineer
919.266.8604 or chris.thomas@schneider-electric.com

TOPP INDUSTRIES INC.**P.O. Box 420, Highway 25 North****Rochester, IN 46975****Phone: 800/ 354-4534 ■ FAX: 574/223-6106**Web Site: www.toppindustries.com*Products:* AC, BS, GR, LA, PS, PB, SE, WW, OO
(Structural Foam Basins and Prefabricated Lift
Stations)*Sales Contacts:* Ed Kelso, Sales.574/224-8653. ekelso@toppindustries.com

Timothy Merkel, Outside Sales Manager.

419/908-7612. tmerkel@toppindustries.com*Technical Contact:* Judy Terry, Engineered Sales
and Customer Service. 574/224-8653.jterry@toppindustries.com

U.S. SYNTHETIC**1260 S. 1600 West, Orem, UT 84058****Phone: 801/235-9001 ■ FAX: 801/235-9141**Web Site: www.ussynthetic.com*Sales Contact:* Dan Bagley, Business Development.rdbagley@ussynthetic.com

VAL-MATIC VALVE & MFG. CORP.**905 Riverside Drive, Elmhurst, IL 60126****Phone: 630/941-7600 ■ FAX: 630/941-8042**Web Site: www.valmatic.com*Products:* VA*Sales Contact:* Diane Meyer, Marketing Manager.

630/993-4022. FAX: 630/993-4087.

dmm@valmatic.com*Technical Contact:* Ed Gardner, Account Manager.

630/993-4018. FAX 630/941-8042

edg@valmatic.com

SWPA'S INDUSTRY "COMMUNITY"

SWPA created its Associate Member category (non-manufacturers) because the Association understands that it is in need of balanced input from the entire submersible wastewater pumping system "community" and that distributors, reps, consulting and specifying engineering firms, service stations, systems packagers, publishers, and others providing services related to Industry Products* and/or who provide services to users of Industry Products represent a vitally important segment of this "community."

The "community of interest" and influence associated with these products is much larger than the manufacturers of the pumps and the component parts and accessories for lift stations and grinder pump stations.

To continue to be successful in today's rapidly changing business environment, associations like SWPA need broad-based input to make sound decisions and to ensure that its programs and services meet not only its members' expectations but also market expectations.

To assist in promoting the interests of the entire industry, Associate Members are invited to serve on SWPA's committees, subcommittees, and working groups where their knowledge, expertise, and input are vital in creating balanced educational and training products.

Their participation in these programs and activities broadens SWPA's perspective of to the full submersible wastewater pump industry supply chain, the

SWPA CREATED ITS ASSOCIATE MEMBER CATEGORY BECAUSE THE ASSOCIATION UNDERSTANDS THAT IT IS IN NEED OF BALANCED INPUT FROM THE ENTIRE SUBMERSIBLE WASTEWATER PUMPING SYSTEMS "COMMUNITY" AND THAT NON-MANUFACTURERS REPRESENT A VITALLY IMPORTANT SEGMENT OF THIS "COMMUNITY."

community of interest and including end-users; to broaden influence associated with submersible wastewater pumps; and to bring new resources and experience to the Association and help achieve a better balance of interest.

This is of particular importance as SWPA develops additional Standards, industry guidelines, educational training programs, and technical publications in accordance with its strategic initiative to promote "*The Systems Approach*".

THE ROLE OF THE DISTRIBUTOR

One of the principal players in this "community" is the distributor (or sometimes referred to as the rep), who plays a vital role in the application, sale, and service of submersible wastewater pumps.

Distributors don't manufacture pumps and they may or may not install pumps, but their role is nonetheless a vital one in our market. It is the responsibility of the distributor to sell pumps and (end users, installer, etc.).

Distributors target a predeter-

mined geographic market area or industry segment as agreed upon between the distributor and the manufacturer(s) they represent. Traditionally, the most profitable relationships are those with exclusivity of representation.

Through strong distribution, a manufacturer can reach vast markets armed with the local knowledge and other intangibles outlined below without in-house overhead of a direct sales force. The costs of the sales process is primarily shouldered by the distributor during the pursuit of the sale, thus allowing the manufacturer to invest more heavily in product development and production improvements.

Distributors earn sales (and therefore profits) through the proper application of their resources which include engineering principles (mechanical, hydraulic, chemical, and electrical), local system knowledge (historical as well as predictive), successful relationships (with engineers, contractors, owners, etc.), and specific product capabilities (by brand, style, etc.).

The distributor relies upon these intangibles (intellectual properties) to secure sales of tangible products. In a market that seems commodity driven, wastewater pump sales are still an engineered field.

* For membership purposes, SWPA defines Industry Products as: Industry Products are defined as submersible wastewater pumps that can efficiently handle solids.

ASSOCIATE MEMBER LISTINGS

Associate Members are non-manufacturers providing services related to Industry Products and/or who provide services to users of industry products.

ALASKA PUMP & SUPPLY, INC.

261 East 56th Ave., Bldg A, Anchorage, AK 99518
Phone: 907/563-3424 ■ FAX: 907/562-5449
 Web Site: akpump@alaska.net
Company Description: DIST, SVSTA, SYSTP
Sales and Technical Contact: Terry Gorlick,
 President. akpump@alaska.net

ALLEN'S ELECTRICAL & PLUMBING

225 JC Cannady Rd., Statesboro, GA 30458
Phone: 912/764-9975 ■ FAX: 912/681-2970
Company Description: O
Sales Contact: Barney Allen, Jr. Owner.
 912/682-2384. blallen@frontiernet.net

B&M TECHNICAL SERVICES, INC.

364 Industrial Drive, P.O. Box 48
 Coloma, WI 54930
Phone: 715/228-7604 ■ FAX: 715/228-3418
 Web Site: www.bmtechservice.com
Company Description: REP, SVSTA, SYSTP
Sales Contact: Katie Gruber, Sales Manager.
 715/228-7604 608/547-9422 (Cell)
Katie@bmtechservice.com
Technical Contact: Josh Gruber, Vice President.
 608/547-2407. Josh@bmtechservice.com

BLAKE EQUIPMENT CO., INC.

4 New Park Road, East Windsor, CT 06088
FAX: 860/243-3996
 Web Site: www.blakeequip.com
Company Description: DIST, SVSTA, SYSTP
Sales and Technical Contact: Robert Klybas, Vice
 President. Bob.Klybas@blakeequip.com
 Christine Russo, Sales & Manufacturing.
 860/218-1006.

BROWN & CALDWELL

1600 Duke Street, Suite 310, Alexandria, VA
 22314
Phone: 703/739-4212 ■ FAX: 860/528-8057
 Web Site: www.brwnald.com
Company Description: CE
Contact: Thomas Decker 703/739-4217.
tdecker@brwnald.com

BURNS & MCDONNELL

3650 Mansell Rd., Suite 300, Alpharetta, GA 30022
Phone: 770/510-4541 ■ FAX: 770/587-4772
 Web Site: www.burnsmcd.com
Products: CE
Sales Contact: Matt Bracewell, Regional Manager
 Water. mbracewell@burnsmcd.com

CDM SMITH

One Cambridge Place, 50 Hampshire Street,
 Cambridge, MA 02139
Phone: 617/452-6000 ■ FAX: 617/452-8000
 Web Site: www.cdmsmith.com
Services: CE
Technical Contact: Ernie Sturtz, P.E., BCEE
 850/386-9507. sturtzec@cdmsmith.com

ENGINEERED EQUIPMENT SALES

1814 South Third Street, St. Louis MO 63104
Phone: 314/646-0074 ■ FAX: 314/646-0078
Company Description: REP
Sales Contact: Michael D. Busse, President

G.A. FLEET ASSOCIATES

55 Calvert St., Harrison, NY 10528
Phone: 914/835-4000
 Web Site: www.gafleet.com
Company Description: REP, DIST, SYSTP, SVSTA, O
Sales Contact: Jamie Saxe, Business Development
 Manager. 914/-381-7926. FAX: 914-835-1331.
jsaxe@gafleet.com

GANNETT FLEMING, INC.

207 Senate Ave., Camp Hill, PA 17011
Phone: 717/763-7211 ■ FAX: 717/763-8150
 Web Site: www.gfnet.com
Company Description: CE
Sales Contact: Jeffrey L. Raffensperger
 717/763-7212. jraffensperger@gfnet.com

HARMON & Co., INC.

195 White Oak Hill Rd., Poland, ME 04274
Phone: 207/998-8100 ■ FAX: 207/998-2484
Company Description: REP
Sales Contact: Greg Harmon, President.
 207/998-8100. greg.harmonco@gmail.com

MILBY COMPANY

6201 S. Hanover Rd., Elkridge, MD 21075
Phone: 410-796-7700 ■ FAX: 410/796-7739
 Web Site: www.milbycompany.com
Company Description: REP, DIST, SYST, SVSTA, O
Sales/Technical Contact: Chris Lind, Business
 Development Manager. 512/858-7927.
clind@milbyco.com

MODERN PUMPING TODAY

312 Lorna Square, Birmingham, AL 35216
Phone: 205/795-0232
 Web Site: www.modernpumpingtoday.com
Company Description: magazine, website,
Editorial Contact: Jay Campbell, Editor.
Jay@modernpumpingtoday.com

PENNWELL

1421 S. Sheridan, Tulsa, OK 74112
Phone: 918/832-9237 ■ FAX: 918/831-9834
 Web Site: www.waterworld.com
Company Description: Publisher
Sales Contact: Dottie LaFerney, National Sales
 Manager. 512/858-7927. dottieL@pennwell.com
Technical Contact: James Laughlin, Associate
 Publisher. 918/832-9320. jamesL@pennwell.com

PRECISION PUMP & VALVE SERVICE, INC.

P. O. Box 7027, 517 Old Goff Mountain Road,
 Charleston, WV 25356
Phone: 304/776-1710 ■ FAX: 304/776-0303
 Web Site: www.ppvs.com
Company Description: DIST, SERV
Sales Contact: James Landfried, Municipal Sales.
jlandfried@ppvs.com
Technical Contact: James Lawson, Sales
 Engineering. jlawson@ppvs.com

PREFERRED SOURCES, INC.

930 Culp Rd., Pineville, NC 28134
Phone: 704/504-3111 ■ FAX: 704/504-3499
Company Description: REP, SVSTA, SYSTP
Sales Contact: Scott Taylor, Sales Manager.
 980/721-4872. ScottTaylor@preferredsources.com
Technical Contact: Josh Amon, Vice President.
 704/504-3111, EXT. 200.
JoshAmon@preferredsources.com

PUMPS & SYSTEMS MAGAZINE

1900 28th Avenue South, Birmingham, AL 35209
Phone: 205/212-9402 ■ FAX: 205/314-8272
 Web Site: www.pumpsandsystems.com
Company Description: magazine, website,
 e-newsletters, webinars, eblasts
Editorial Contact: Alecia Archibald, Senior Editor.
aarchibald@cahabamedia.com

SMITH PUMP COMPANY, INC.

301 M & B Industrial, Waco, TX 76712
Phone: 254/776-0377 ■ FAX: 254/776-0023
 Web Site: www.smithpump.com
Company Description: DIST
Sales and Technical Contact: L. Granger Smith,
 President. granger@smithpump.com

SOUTHEASTERN PUMP

1368 SW 12th Avenue, Pompano Beach, FL 33069
Phone: 954/781-8400 or 800/396-4182
FAX: 954/781-8434
 Web Site: www.sepump.com
Company Description: DIST, REP, SYST
Sales and Technical Contact: John Veerling
 (M, T), President.
jveerling@sepump.com

TECHNICAL SALES CORPORATION**4621 N. Hale Ave., Tampa, FL 33614****Phone: 813/876-9256 ■ FAX: 813/874-1194**Web Site: www.tsctampa.com

Company Description: DIST, SVSTA, SYST

Sales Contact: Ben Larsen, President.

ben@tsctampa.com

CHARLES R. UNDERWOOD, INC.**2189 Everett Dowdy Road, Sanford, NC 27330****Phone: 919/775-2463 ■ FAX: 919/708-7232**

Company Description: CE, DIST, SVSTA

Sales Contact: Mitchell McCoy, Electrical Division Manager.

Technical Contact: Zach Purvis. 919/775-2463.

WATERMARK ENGINEERED PRODUCT SALES, INC.**17220 Harger Court, Noblesville, IN 46060****Phone: 317/219-4333 ■ FAX: 317/219-3370**Web Site: www.watermarkeps.com

Company Description: REP, SYSTP

Sales Contact: Brad Boyer, Owner.

317/219-4324. bboyer@watermarkeps.com

Technical Contact: Joel Warden. 317/219-4325.

jwarden@watermarkeps.com

WHITNEY EQUIPMENT COMPANY**21222 30th Drive SE, Suite 110****Bothwell, WA 98021****Phone: 425/486-9499 ■ FAX: 425/485-7409**

Company Description: DIST, REP, SVSTA, SYSTP

Sales/Technical Contact: Jason Morse.

503/310-9893. jmorse@weci.com

WWEMA**P.O. Box 17402, Washington, DC 20041**

Company Description: 0

Contact: Vanessa Leiby, Executive Director.

703/444-1777. vanessa@wwema.org

ADVERTISERS INDEX

SWPA MEMBER ADVERTISING APPEARS ON THE FOLLOWING PAGES IN A STANDARDIZED TWO-PAGE FORMAT. A PROFILE, INCLUDING, A COMPANY DESCRIPTION*, SALES AND TECHNICAL CONTACT PERSONS AND THE COMPANY'S LOGO, APPEARS AT THE TOP OF THE LEFT-HAND PAGE WITH ADVERTISING ON THE BOTTOM HALF OF THE LEFT-HAND PAGE AND THE FULL RIGHT-HAND PAGE.

CRANE PUMPS & SYSTEMS.....	44
EBARA.....	46
EMPOWERING PUMPS.....	48
ENVIRONMENT ONE CORPORATION.....	50
G.A. FLEET ASSOCIATES.....	52
FLOMATIC CORPORATION.....	54
XYLEM FLYGT PRODUCTS.....	56
FRANKLIN ELECTRIC COMPANY..	58
THE GORMAN RUPP COMPANY.....	60
GOULDS WATER TECHNOLOGY A XYLEM BRAND.....	62
GRUNDFOS WATER UTILITY.....	64
HOMA.....	66
KSB, INC.....	68
MILBY COMPANY.....	70
MODY PUMPS, INC.....	72
MOTOR PROTECTION ELECTRONICS (MPE).....	74
OHIO ELECTRIC CONTOL, INC.....	76
PENTAIR.....	78
PUMPS & SYSTEMS MAGAZINE.....	80
ROCKWELL AUTOMATION, INC.....	82
SCHNEIDER ELECTRIC/SQUARE D.....	84
SJE RHOMBUS.....	86
SULZER PUMP SOLUTIONS.....	88
TOPP INDUSTRIES INC.....	90
VAL-MATIC VALVE & MFG. CORP.....	92
WEIL PUMP COMPANY, INC.....	94
ZOELLER ENGINEERED PRODUCTS.....	96

** The individual company descriptions have been supplied by the advertiser. SWPA assumes no liability for the accuracy of any of the statements or claims presented in that information.*

CRANE PUMPS & SYSTEMS

420 Third Street
 Piqua, OH 45356
 Phone: 937/214-5325
 FAX: 937/773-2238
 Web Site: www.cranepumps.com



Products: CP, DP, GP, IP, SH, TP, OP (Sewage Injector and Effluent Pumps), AC, AT, BS, CC, CP, CT, EM, GR, LA, PC, PM, PS, SE, SS VA, VFD, WW OO (Liquid Level Controls)

Technical Contact: Chuck Drake, Product Manager Submersible Pumps.

937/615-3578. cdrake@cranepumps.com

Sales Contact: Walt Erndt, VP/GM of Municipal.

937/778-3504. werndt@cranepumps.com

Crane Pumps & Systems is a manufacturer of high quality pumps, systems, accessories and services. With brands you trust, we provide solutions for commercial building, residential building, industrial, municipal and military markets. With over a century of experience CP&S serves the ever changing needs in today's pumping marketplace. Our commitment to excellence is carried through to the manufacturing, sales, distribution and service components of our business. Finding solutions and creating better processes make CP&S who we are. Our slogan "Everyone. Everywhere. On time. Every time" fuels our employees to strive to bring the most durable and sustainable pumps to market.

CRANE PUMPS & SYSTEMS

Highly engineered municipal product breadth in wastewater, pressure sewer, clean water and dewatering make CP&S the complete package solutions.



Crane Pumps & Systems • (937) 778-8947 • www.cranepumps.com



CRANE PUMPS & SYSTEMS

Providing Municipal Solutions with long lasting dependability from **brands you trust.**



- Superior service life from quality brands
- Solution for virtually any municipal application
- Industry leading innovation
- Reduced costs and maintenance

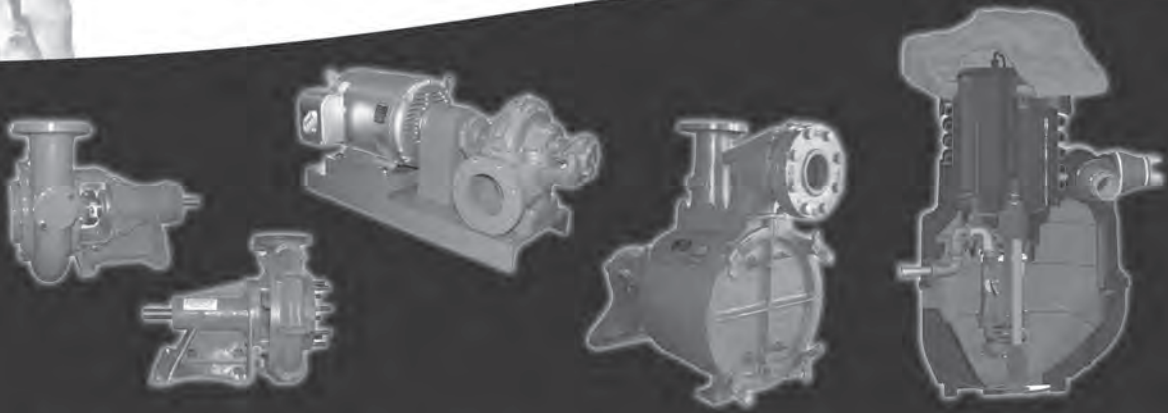

BARNES

burks

DEMING

WEINMAN

CROWN

PROSSER

EBARA

1651 Cedar Line Drive
Rock Hill, SC 29730

Phone: 803/327-5005

FAX: 803/327-5097

Web Site: <http://www.pumpsebara.com>



Products: CP, DP, GP, IP, SH, OP

Sales/Technical Contact: Customer Service

803/327-5005. customer_service@pumpsebara.com

Founded in 1912, EBARA Corporation is recognized as a world leader in the design, development and manufacture of industrial machinery with a predominant focus on the production of pumps, pumping systems and compressors. EBARA International Corporation (EIC), represents the North American portion of the global pump and fluid machinery manufacturer, encompasses three divisions, Cryodynamics, Fluid Handling and North American Custom Pump.

The Fluid Handling Division provides engineered pump, pump products and related services for the water, wastewater, sewage, commercial, building services, industrial, and municipal industries offering reliable product knowledge, application expertise and responsive support including aftermarket replacement parts services. EBARA remains the largest single brand pump company in the world and develops high quality, efficient products and key system components for the fields of water supply, energy and environmental issues. Recognizing the continued strain on infrastructures and water and wastewater facilities with increased maintenance, energy, and environmental demands and costs, EBARA strives to deploy the best water, wastewater pumps, products, and technologies to meet these requirements.

ENGINEERED for PERFORMANCE

EBARA Model DLKF series pumps are designed to tackle clogging challenges with enhanced passage capabilities for handling of fibrous waste.

Key Features

- Reduces material caught on the vane tips
- Increases inlet pressure which keeps debris moving instead of recirculating
- E-liminator groove disrupts the accumulation of fibrous debris



EBARA

EBARA International Corporation

Fluid Handling Division

www.pumpsebara.com

©2015 EBARA International Corporation, All rights reserved.

Water and Wastewater Pump Products **ENGINEERED** for **SOLUTIONS**

Packaged Pump Systems

EBARA Fluid Handling packaged pump systems are designed and built in the U.S. to suit your wastewater or sludge handling requirements.

- Sole source responsibility for complete station provided by EBARA Fluid Handling
- R7 fiberglass enclosure with large doors
- Pre-cast steel reinforced polymer concrete base for unparalleled resistance to corrosive attack from H₂S
- 4" & 6" discharge piping available, with optional bypass connections
- Penetrations for the piping and cables are sealed from the wet well to prevent harmful gases from entering the enclosure.
- 2 through 60HP EBARA pumps handle up to 1200 GPM and 3" diameter solids
- Complete station covered by a comprehensive manufacturer's warranty
- EBARA Fluid Handling maintains over \$8 million in inventory to provide industry leading response to your need for submersible pumps

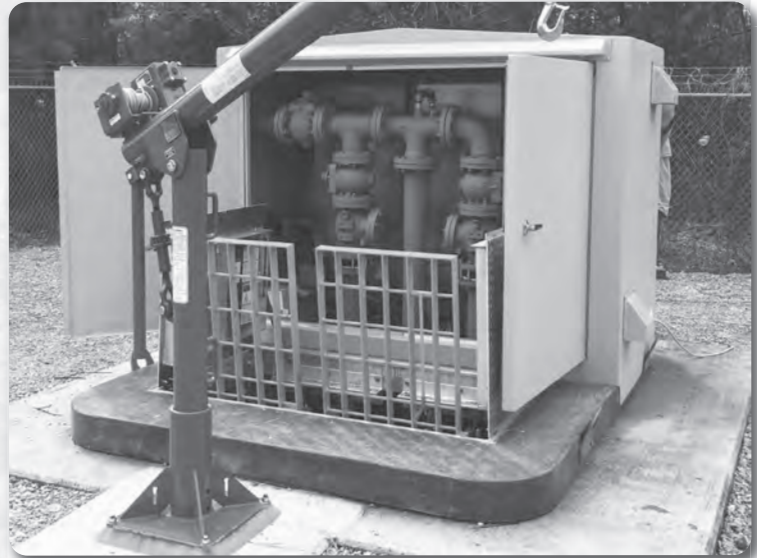

City of Southside, AL Installation Emergency Lift Station Rehabilitation

End User: Southside Water Works and Sewer Board
Industry: Municipal Wastewater, Sewage
Solution: EBARA EP1 duplex packaged pump system
 Two, 30 HP submersible model DLKFU pumps
 Rated to deliver 150 GPM at 145' TDH
 K-Series impeller design

The station was installed and on line at the end of the second day – it was a very quick retrofit, which kept downtime and bypass pumping to a minimum.

Scan the code to watch the full story!



EBARA

EBARA International Corporation
 Fluid Handling Division
www.pumpsebara.com

EMPOWERING PUMPS, LLC

P. O. Box 2313
 Tuscalousa, AL 35403
 Phone: 205/391-8422
 Web Site: www.EmpoweringPumps.com



Products: Magazine, websites, enewsletters
Sales Contact: Charli Matthews, Publisher/President
 205/391-8422. charli@empoweringpumps.com

Founded in 2011, Empowering Brands is a digital media company that has created the leading online information and connection hub for the global pump industry, EmpoweringPumps.com. As strategic business partners to our clients, Empowering Brands creates tailored programs to support our clients’ marketing campaigns, providing flexible and responsive service. With broad industry knowledge and a respected brand, Empowering Brands provides best-in-class digital media, content development, and social media strategy to empower our clients to cost-effectively reach and engage with a diverse industrial audience across multiple market industry platforms.

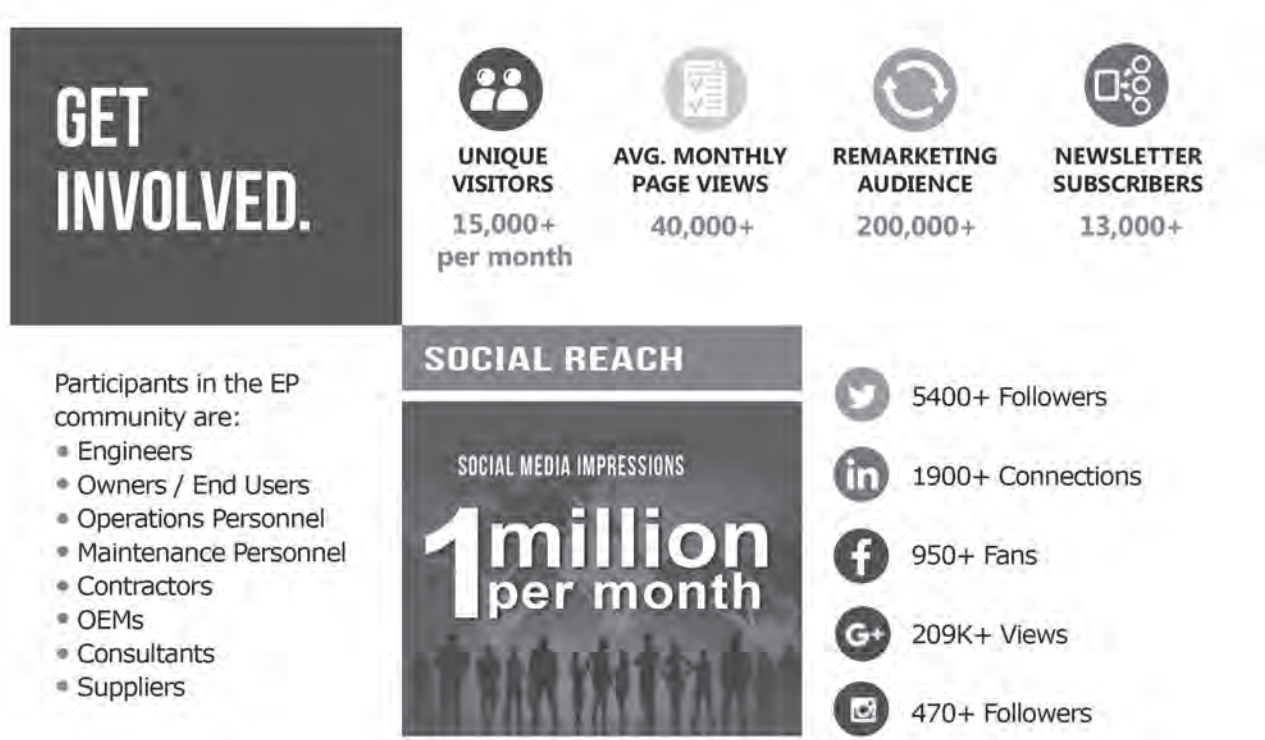

Places to Go:

~~o New York~~

~~o London~~

~~o Paris~~

o EmpoweringPumps.com

Empowering Pumps **connects** the pump systems community through our network of websites, e-newsletters, and social media, providing a multi-channel platform for people in the pump industry to *engage* each other.

People working directly with pumps and pump systems use EP as a resource for industry news, product information, case studies, videos, event details, training opportunities, and to exchange ideas in our online forum.

Equipment manufacturers and service providers partner with EP to share technical knowledge and thought leadership that only their experts can provide.

Industry-leading organizations collaborate with EP to share information on best practices, states of the industry, and opportunities for continuing education.

Get involved. www.EmpoweringPumps.com  @empoweringpumps #pumptalk



EMPOWERING PUMPS™
CONNECTING THE PUMP SYSTEMS COMMUNITY

ENVIRONMENT ONE CORPORATION

2773 Balltown Road

Niskayuna, NY 12309

Phone: 518/346-6161

FAX: 518/346-6188

Web Site: www.eone.com*Products:* GP, CT*Sales Contact:* Chris Greco, Director of Sales

cgreco@eone.com

Technical Contact: Clark Henry, Vice President of Engineering.

chenry@eone.com

Low-pressure, gravity-independent, contour-following sewage collection systems were pioneered by Environment One. E/One Sewer® systems have proven to be an economical and effective method of sewerage otherwise difficult land areas, such as lakefront property, hilly terrain, very flat land, and areas with high water tables. At the heart of an E/One Sewer is the Grinder Pump, developed by Environment One. These units accept household sanitary waste, grind it into fine slurry, and pressurize it to permit transport through small-diameter pipes. E/One sewer systems serve more than 1 million end-users daily.



There's
no limit to
where we
can go.

Environment One Corporation is an operating company of Precision Castparts Corp., an international provider of complex metal parts and industrial products.

With corporate headquarters in New York and regional offices and distribution throughout the industrialized world, Environment One is a manufacturer and provider of:

- Products and services for the disposal of residential sanitary waste
- Utility systems for the protection and performance optimization of electric utility assets



A Precision Castparts Company

2773 Balltown Road
Niskayuna, NY 12309
Voice 518.346.6161
www.eone.com



GENUINE
 — **E/One-DRIVEN** —
ALL-TERRAIN
SEWER™

Are you dealing with failing septic tanks?

Is I&I from your existing sewer system eating up your budget?

Do you have a sewer project with challenging terrain looming ahead?

Get after it.

ALL-TERRAIN SEWER™ low pressure systems from E/One give you the freedom to sewer anywhere.

Environmentally sensitive, economically sensible™: ALL-TERRAIN SEWER low pressure systems are significantly more affordable than conventional gravity sewers, safer than septic systems, and they're a light touch on the land.

Plus, our ALL-TERRAIN SEWER low pressure systems carry a proven track record of reliability with the lowest system life-cycle costs in the industry.

Whether it's dead or dying septic tanks or expensive inflow and infiltration, we can help. Learn more at allterrainsewer.com



E/One, ALL-TERRAIN SEWER and Environmentally Sensitive Economically Sensible are trademarks of Environment One Corporation. Copyright 2016 Environment One Corporation. All rights reserved throughout the world.

G.A. FLEET ASSOCIATES

55 Calvert Street

Harrison, NY 10528

Phone: 914/835-4000

Web Site: www.gafleet.com*Products:* REP, DIST, SYSTP, SVSTA, O*Sales Contact:* Jamie Saxe, Business Development. Manager. 914/-381-7926. FAX: 914-381-7931.
jsaxe@gafleet.com

GA Fleet Associates serves Building Trades, Municipal, Transit, and After Market clients by providing equipment, systems, direction, and service for their projects. Our staff is comprised of degreed engineers, MBAs, and highly trained technicians ready to solve any technical or field problem.

We specialize in plumbing and fire protection pumping systems, the HVAC large pump market, and municipal water and waste pumping systems. We also work with airports and in the subway to facilitate water drainage, heating and treatment needs.

The Fleet Pump & Service Group is dedicated to aftermarket equipment, with mechanics, technicians, service, parts, rentals, and service contracts.

A black and white advertisement for G.A. Fleet Associates. The background is a night-time photograph of a city skyline, with the Freedom Tower being the most prominent building. The text is overlaid on the right side of the image. At the bottom left, the website 'gafleet.com' is listed. At the bottom right, the company logo (stylized waves) and the word 'FLEET' are displayed.

SIXTY YEARS.
THOUSANDS OF
PROJECTS.
COUNTLESS DETAILS.
**WE HAVE YOU
COVERED.**

gafleet.com

FLEET



WHEN IT
COMES TO
MANAGING
FLOOD
RISK...

Think Fleet First.

As a municipal agency, building owner,
consulting engineer or contractor you
should be thinking urban resilience.

DETECTION.
PUMPS.
HARDENED CONTROLS.
EMERGENCY SERVICES.

WE HAVE YOU COVERED.

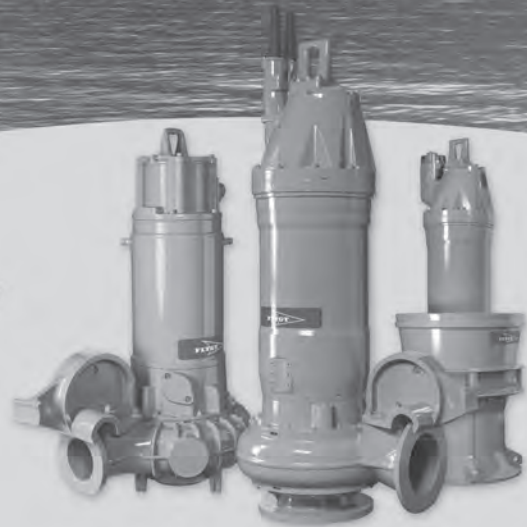

FLOMATIC CORPORATION

15 Pruyn's Island Drive

Glens Falls, NY 12801

Phone: 518/761-9797

FAX: 518/761-9798

Web Site: www.flomatic.com

*Products: VA**Sales Contact:* Nick Farrara, Vice President of Sales. 518/832-6767.

FAX: 518/761-9798. nick@flomatic.com

Technical Contact: Brian Allen, Design Engineer. 518/761-9797, Ext. 238

FAX: 518/761-9798. allen@flomatic.com.

Flomatic is the leading worldwide manufacturer of valves — specializing in Air Valves, Automatic Control Valves, Check and Foot Valves. For more than 80 years we have been changing the industry and leading the market with distinctive patented products. We offer a full line of Check Valves for the water and wastewater market ranging from 1" to 30". Our products have been installed in a wide variety of applications with excellent results. Flomatic is an ISO 9001 and 14001 certified company with comprehensive manufacturing processes. As always, Flomatic is dedicated to providing their customers with **High Quality Valves Built to Last**.

Flomatic Valves for all applications

The 90/92 swing checks are built to AWWA C508 specifications 2" - 30". Several different models are available with single and double air dash pots with springs or weights. Other swing checks (model 78) angle body with flapper are available. Call Flomatic at 1-800-833-2040 for complete details on Flomatic's exciting new angle body.

**408 Ball Check Valve is maintenance free, giving you time for golf or fishing**

Flomatic model 408 ball check valve is a non-clog fullported check valve for storm water and waste water applications.

These valves are main-

tenance free and

are epoxy

coated with

NSF approved

powder. They

feature a Buna-

N self-cleaning ball with stainless steel bolts. The Flomatic ball

checks will give you years of trouble free service.



TAKE CONTROL



- 745 - Flo-Flex® Check Valve
- 745PI - Flo-Flex® Check Valve with Position Indicator
- 745BF - Flo-Flex® Check Valve with Backflush Device
- SEWAIR - MAXI® Air Release Valve

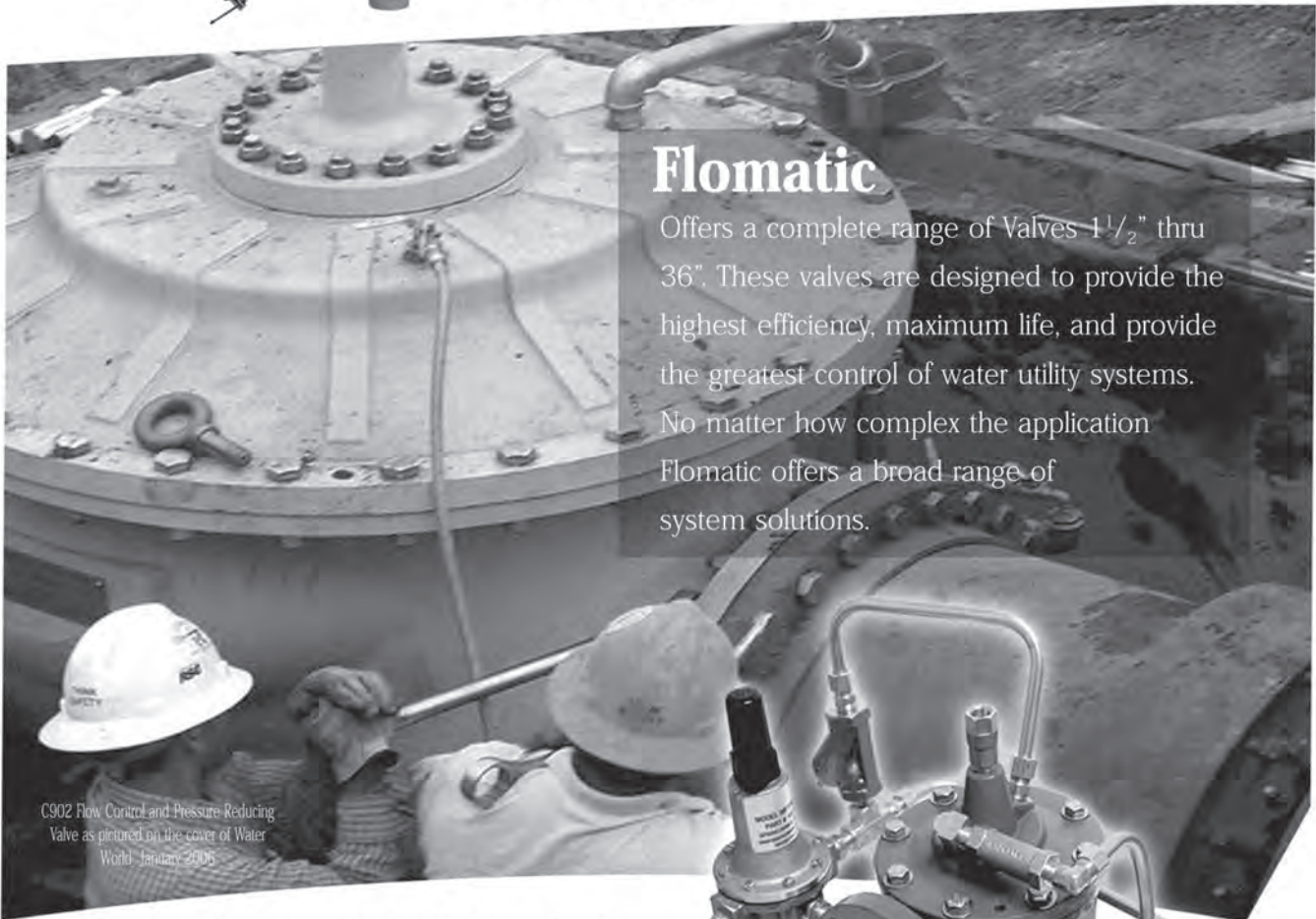

Flomatic

Offers a complete range of Valves 1 1/2" thru 36". These valves are designed to provide the highest efficiency, maximum life, and provide the greatest control of water utility systems. No matter how complex the application Flomatic offers a broad range of system solutions.

C902 Flow Control and Pressure Reducing Valve as pictured on the cover of Water World - January 2006

For more information about our 754 Swing Check Valves, Sewair-Maxi or any of our other products:
 Call: Flomatic at (800) 833-2040
 or visit us on the web at www.Flomatic.com

Flomatic

High Quality Valves Built to Last...

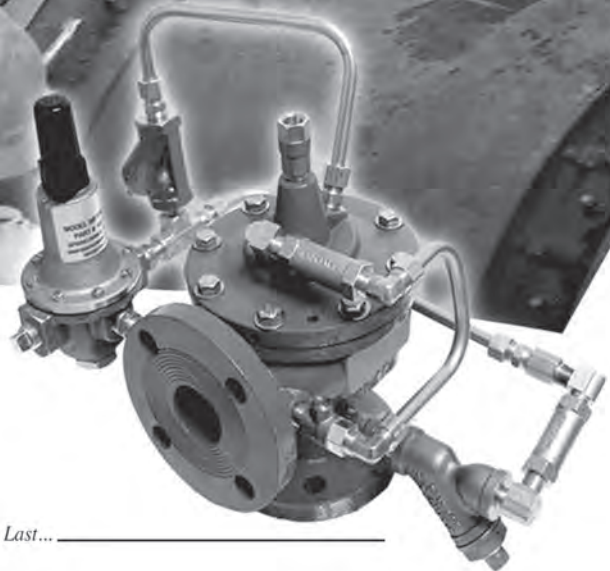

XYLEM FLYGT PRODUCTS

14125 South Bridge Circle
Charlotte, NC 28273

Phone: 704/409-9750

FAX: 704/409-9800

Web Site: <http://www.flygt.com/en-us> or www.xyleminc.com/us



Products: AP, CP, DB, GP, IP, SH, TP, AC, BS, CC, CP, CT, GR, LA, PM, PB, SS, VA, VFD, WW

Sales Contact: Lisa Riles – Business Development Manager, Wastewater Pumps

lisa.riles@xyleminc.com

Bob Domkowski – Engineering Consultant

bob.domkowski@xyleminc.com

Xylem's Flygt brand is the inventor and the world leader in the design, manufacture, and sale of heavy-duty electric submersible solids-handling pumps, axial flow high volume propeller pumps, mixers, flow generating equipment and monitoring and control systems. Flygt submersible pump products range in size from 1-hp to beyond 1,000-hp with the ability to handle wastewater and storm water flows to beyond 100,000 gpm per pump. Flygt's N-Pump delivers sustained high hydraulic efficiency and is the premier innovative solids-handling pump technology in the wastewater industry. The result is the most consistent offering of proven equipment for the widest range of pumping and mixing applications. Visit our website for more information at <http://www.flygt.com/en-us>.

FLYGT SUBMERSIBLE WASTEWATER N-PUMPS.

**PROVIDING CUSTOMERS
WITH SUSTAINED
HIGH EFFICIENCY,
LESS DOWNTIME
AND LOWER
OPERATING
COSTS.**



**THE WORLD'S
LARGEST
MANUFACTURER
OF HEAVY-DUTY
SUBMERSIBLE
PUMPS AND
MIXERS.**



a xylem brand

FRANKLIN ELECTRIC

9255 Coverdale Rd., Fort Wayne, IN 46809
 Phone: 888-885-8989 | Fax: 260-827-5654
 Web Sites: www.franklinengineered.com | www.littlegiant.com

Products: CP, GP, IP, SH, AC, AT, BS, CC, CP, CT, GR, LA, PC, PM, PB, SE, SS, VA, VFD

Sales Contact: Twain Glaser
 717-504-2625 | tglaser@fele.com

Technical Contact FPS: Jessie Hinthner
 405-440-1390 | jhinther@fele.com

Technical Contact Little Giant: Randy Tucker
 405-440-1347 | rtucker@fele.com

FPS Engineered Products: From non-clog and grinder pumps to booster pumps, our dedicated team directs field engineers, architects, and installers down the most efficient path by providing proper sizing requirements, affordable quote options, and reliable product solutions. To learn more, visit your distributor or www.franklinengineered.com

Little Giant Pumps: From water pumps, water systems, HVAC, industrial pumps to on-site water treatment systems, our products' breadth and depth offer meaningful advantages to residential, light commercial, industrial, and agricultural customers alike. To find out more, visit your distributor or www.littlegiant.com



FPS ENGINEERED PRODUCTS

Submersible Non-Clog Pumps



3NC & 4NC Series Non-Clog Pumps

High Head Grinder Pumps

IGPH-M & IGPH-A Series
High Head Grinder Pumps



Submersible Cistern Pumps

C1 Series Submersible
Cistern Pumps

Utility Pumps



5-MSP Utility Pump

Sewage Pumps



9SN-CIA-RF Sewage Pump



10SN-CIA-SFS Sewage Pump



20S-CIM 2HP Sewage Pump

Sump Pumps



WRS-9EN Water Removal System



6EC-CIA-SFS Automatic Sump Pump



6-CIA Submersible Sump Pump

Wastewater Packaged Systems

Pit+Plus Premium Simplex Systems



Sewage Grinder Pumps

GP-A231 Sewage Grinder Pump



Effluent Pumps

10ENH-CIA-RF High Head Effluent Pump



6EC-CIM Effluent Pump



16EH-CIM High-Head Effluent Pump



Sewage Grinder Package Systems



GP-SMPX

LittleGIANT

THE GORMAN-RUPP COMPANY

600 S. Airport Rd.

Mansfield, OH 44903

Phone: 419/755-1011

FAX: 419/755-1251

Web Site: www.GRpumps.com*Products:* CP, DP, IP, SH, OP (self-priming centrifugal, rotary gear), CT, LA, PM*Sales/Technical Contact:* Vince Baldasare, Sales Manager, Engineered Systems.Phone: 419/755-1271 FAX: 419/755-1208. vbaldasare@gormanrupp.com

A world leader in municipal sewage pumping systems. Manufacturing an extensive line of above and below ground packaged pumping systems as well as submersible pumping systems, booster stations, silent pumps, and controls. The pre-engineered systems include pumps, motors, valves, controls, etc.

SF Series[®]

GRPUMPS.COM

 *The Pump People[®]*

The advertisement features a collection of SF Series pumps of various sizes and configurations, arranged on a white, curved platform against a dark background with geometric patterns. The pumps have a distinctive ribbed, cylindrical design. In the bottom left corner, there is a QR code and the website address GRPUMPS.COM. In the bottom right corner, the Gorman-Rupp Pumps logo is displayed alongside the slogan 'The Pump People' in a script font.



reliableliftstations.com

DISCOVER RELIABILITY

THAT'S MORE THAN SURFACE-DEEP.

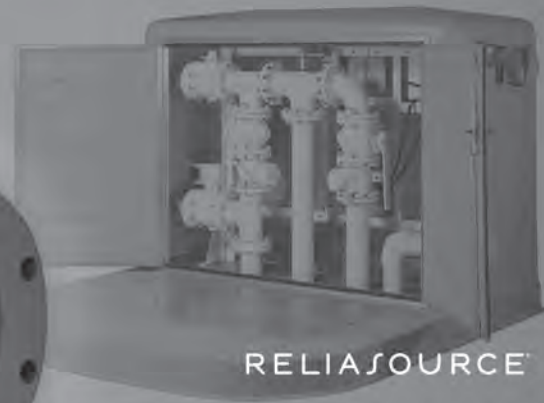

RELIASOURCE

SF SERIES® PUMPS AND RELIASOURCE® ASVP TEAM UP TO DELIVER THE INDUSTRY'S MOST RELIABLE SUBMERSIBLE SEWAGE-HANDLING SOLUTION.

The first 100% Gorman-Rupp-manufactured solids-handling submersible pump, SF Series® solids-handling pumps deliver renowned Gorman-Rupp quality in an affordable submersible model. These pumps feature premium efficiency motors and a unique 8-sided design providing optimal heat dissipation and superior motor cooling for increased motor life. Pair your SF Series® pump with the ReliaSource® Above-Ground Submersible Valve Package (ASVP), and you get powerful below ground pumping combined with the safety and convenience of above-ground controls and valves. And it's all backed by superior parts availability and an industry-leading warranty.

With Infinity and ReliaSource, you get long-lasting, trouble-free solids-handling pumping performance you can rely on. Guaranteed. **Discover your single source for value, performance, and peace of mind at reliableliftstations.com.**

GORMAN-RUPP PUMPS
P.O. BOX 1217 | MANSFIELD, OHIO 44901-1217 | USA
419.755.1011 | GRSALES@GORMANRUPP.COM | GRPUMPS.COM



The Pump People®

GOULDS WATER TECHNOLOGY A XYLEM BRAND

2881 East Bayard Street Extension
Seneca Falls, NY 13148

Phone: 315/568-7123

FAX: 888/322-5877

Web Site: www.goulds.com



Products: CP, GP, IP, SH, TP, AC, AT, BS, CC,
CP, CT, EM, GR, LA, PS, PB, SE, SS, VA, VFD, WW

Sales Contact: William Gell, Product Manager Wastewater.

315/239-7004. william.gell@xylem.com

Technical Contact: Joe Steinberg, Assistant Product Manager Wastewater.

315/239-2419. joe.steinberg@xylem.com

Goulds Water Technology is an integral part of Xylem Inc., a global leader in manufacturing pumps for residential, commercial, agricultural and municipal markets. The Goulds product portfolio includes submersible, lineshaft turbine, jet pump, sump, effluent, sewage, centrifugals, VFD drives as well as a full line of accessories for those lines.

Applications include:

Residential and Commercial Wastewater: Sump, effluent, and sewage pumps, complete lift stations, stock and custom control panels and accessories designed for residential applications.





LET'S BUILD RESTROOMS FOR 63,000 FANS AND MULTIPLE REFRESHMENTS.

Public venues worldwide rely on our wastewater systems to dispose of waste or drainage quickly, quietly and efficiently. By analyzing your system, we can offer the optimal solution for sewage handling, dewatering and water transfer – and other commercial applications. So let's solve your wastewater challenge with market-leading systems and know-how that help you cut energy, maintenance and life cycle costs. Something we can all cheer about. Visit www.xylem.com/brands/gouldswatertechnology.



© 2014 Xylem Inc.
Goulds is a registered trademark of Goulds Pumps, Inc. and is used under license.

xylem
Let's Solve Water

GRUNDFOS WATER UTILITY

3905 Enterprise Court

Aurora, IL 60504

Phone: 630/236-6900

FAX:

Web Site: www.grundfos.us

Products: CP, GP, IP, SH, TP, AC, AT, BS, CC,
CP, CT, EM, GR, LA, PS, PB, SE, SS, VA, VFD, WW

Sales Contact: Rob Montenegro, Vice President Sales.

rmontenegro@grundfos.com

Technical Contact: Russell Smith, Business Development Manager-Wastewater.

rusmith@grundfos.com

Grundfos is an innovative leader in wastewater pumping solutions and provide comprehensive market coverage through a number of marquee product brands, some with roots going back a century or more. Together, Grundfos, Yeomans, Chicago and Morris gives you access to a submersible range of pumps from the smallest grinder pump to the largest flood control stations, and we are leading the way with not only cutting-edge pump designs but all intuitive dedicated control systems. For more information on how Grundfos is “BRINGING IT ALL TOGETHER” in pump design please visit www.grundfos.us



BRINGING IT ALL TOGETHER

Innovative technologies mean we can offer you the highest total efficiency yet in a wastewater pump – the Grundfos SL range.

- No compromise between hydraulic efficiency and free passage
- Maximizing electrical efficiency
- Intelligently controlling your pump
- Functionality designed for you

be think innovate

www.grundfos.us

GRUNDFOS

BRINGING IT ALL TOGETHER

Innovative technologies mean we can offer you the highest total efficiency yet in a wastewater pump – the Grundfos SL range.



- **No compromise:**
The S-tube impeller offers world class hydraulic efficiency without compromising free passage



- **High motor efficiency:**
Grundfos Blueflux® premium efficiency performance, maximizing electrical efficiency in the pump



- **Intelligent adaptive controls:**
Pump operation controlled intelligently and dynamically with Grundfos controls and remote management



- **Functionality that meets your needs:**
Unprecedented reliability and mechanical efficiency, with smart-design functionality designed for you

be
think
innovate

www.grundfos.us

GRUNDFOS

HOMA PUMP TECHNOLOGY

Fountain Lake Commerce Park, 390 Birmingham Blvd.

Ansonia, CT 06401

Phone: 203/736-8890

FAX: 203/736-8899

Web Site: www.homapump.com



Products: CP, DP, GP, SH, OP (Choppers), AC, BS, CC, CP, CT, EM, GR, LA, PB, SE, SS, VA

Sales Contact: John Lord, Business Development Manager.

JLord@homapump.com

Technical Contact: Ryan Sura, Senior Application Engineer.

RSura@homapump.com

WE GET WATER MOVING

HOMA pumps are installed in more than 100 countries around the world – in countless projects of various kinds. Our know-how = your benefit.

- Submersible grinder pumps with cutter system
- Submersible waste water and sewage pumps
- Packaged pump stations
- Mixers and flow generators
- Injector systems for tank cleaning
- Disposal units
- Control boxes

www.homapumps.com



Intelligent by design.

**HOMA builds pumps that work.
Simple. Reliable. Efficient.**

HOMA pumps are a solid investment.
Our products are known
worldwide for reliability.



203.736.8890

www.homapump.com



Contact Us For A Distributor Nearest You Homa Pump Technology Inc. Connecticut USA

KSB, Inc.

4415 Sarellen Road

Henrico, VA 23231

Phone: 804/222-1818

FAX: 804/226-6961

Web Site: www.ksbusa.com

Products: AP, CP, DP, GP, IP, SH, TP, O (Submersible Pumps and Mixers)

Sales Contact: Sherry Heinly, North America Region Marketing Manager.

sheinly@ksbusa.com

Technical Contact: Dr. T. Ravisundar, Vice President of Technical Services. travisundar@ksbusa.com

Steve Lindgren, Vice President of Sales. slindgren@ksbusa.com

KSB, Inc., a subsidiary of KSB AG, brings to the U.S. more than 140 years of global experience and competence of centrifugal pump technology that is designed for optimum reliability and maximized performance. KSB, Inc. supplies quality water and wastewater pumps and mixers i.e. submersible non-clog sewage, mixed flow, conventional dry pit sewage pumps and submersible mixers. In addition to maintaining manufacturing, testing and repair facilities within the company's headquarters in Richmond, VA, KSB is backed by an established network of sales and service locations to meet customers' needs. KSB continues to increase presence with products and services throughout the U.S. to meet the customers' demands. **Like us on Facebook and follow us on LinkedIn and Twitter. Visit our web site at www.ksbusa.com.**



Your single source partner with leading edge technology!

For 145 years, we are your reliable partner for clean water and efficient wastewater treatment. KSB's innovative solutions and comprehensive information help you meet all water supply and treatment requirements, efficiently and effectively. We offer end-to-end solutions addressing all stages of the water cycle from water extraction to sewage treatment. www.ksbusa.com

► Our technology. Your success.
Pumps • Valves • Service



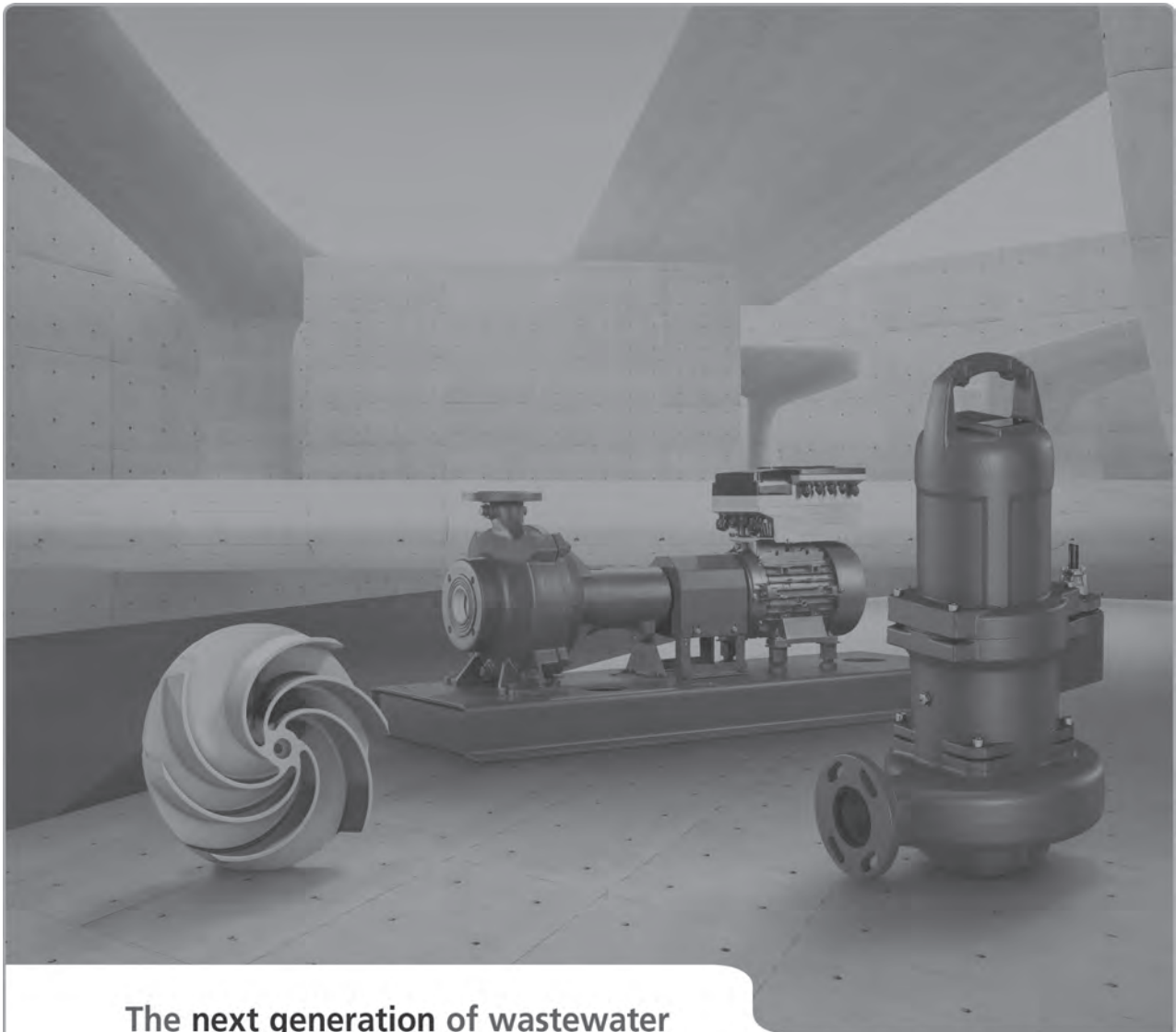

The next generation of wastewater pumps with the new F-Max impeller

The new generation Amarex KRT and Sewatec wastewater pumps in combination with the new F-max non-clogging impeller and high efficiency motors ensure maximum freedom from clogging and overall better energy efficiency.

www.ksbusa.com

► Our technology. Your success.
Pumps • Valves • Service

KSB 

MILBY COMPANY

6201 S. Hanover Rd.

Elkridge, MD 21075

Phone: 410/796-7700

FAX: 410/796-7739

Web Site: www.milbycompany.com*Products:* REP, DIST, SYSTP, SVSTA, O*Sales/Technical Contact:* Chris Lind, Business Development Manager.

clind@milbyco.com

Founded in 1932, Milby Company is the oldest, longest running company serving the water and wastewater industries in the Mid-Atlantic region.



1-800-796-7700 | www.MilbyCo.com
Chris Lind | Business Development Manager
M: 301-752-3363 | E: clind@milbyco.com

Capability Statement

Core Competencies

Milby Company is a regional distributor of water and waste water equipment and accessories. As a small business, Milby Company assists the public engineering services efforts of the Federal Government and its contractors by providing water and wastewater systems products for small and large scale operations and applications.

Products:

Water Systems Pumps and Accessories
Sump, Effluent and Sewage Pumps
Water Conditioning and Treatment
Well Drilling
Plumbing
Geothermal Heat Pump Systems
ASME Certified Tanks
Motors and Controls

Services:

Technical Assistance
Water Testing and Analysis
Equipment Recommendation
Troubleshooting and Problem Solving
Pump Sizing
Pump Testing
Prompt Delivery
Training Classes



Providing Water and Waste Water Solutions

Headquarters

6201 South Hanover Rd.
Elkridge, MD 21075
P: 800-796-7000
F: 410-796-7739

Colonial Heights, VA

860 W. Roslyn Rd. Suite A
Colonial Heights, VA 23834
P: 866-645-2982
F: 804-520-5128

Frederick, MD

7313 Grove Rd. Suite S
Frederick, MD 21704
P: 855-529-0841
F: 240-529-0851

Water Systems

Amtrol	ASME certified Hydronic Tanks, Thermal Expansion Tanks & Pressure Tanks, Shock Surge Suppressors, Fire Protection Systems, Indirect-Fired Water Heaters
Baker-Monitor	Booster Pumps & Booster Stations
Berkeley	Booster Pumps & Booster Stations, Centrifugal & Jet Pumps, Submersible Pumps, Variable Speed Pump Controllers
Flomatic	Commercial Valves
Goulds	Booster Pumps & Booster Stations, Centrifugal & Jet Pumps, Submersible Pumps, Variable Speed Pump Controllers, Turbine Pumps
Sta-Rite	Centrifugal & Jet Pumps, Submersible Pumps, Variable Speed Pump Controllers, High Pressure Boosters
SymCom	Electronic Monitoring Devices, Current Monitors
Rheem	Gas & Electric Commercial Water Heaters

Water Treatment

CSI Water	Filters & Softeners, Ultraviolet Units
Master Water	Filters & Softeners, Reverse Osmosis
LaMotte	Water Testing Equipment
LMI Milton Roy	Chemical Metering Pumps
Pulsafeeder	Chemical Feed Pumps, Metering Pump Controllers
Viqua	Ultraviolet Units

Waste Water

Flomatic	Commercial Valves
Goulds	Lift Stations, Sump, Effluent & Sewage Pumps, Grinder Pumps, Pump/Basin Packages, Specialty Pumps
LMI Milton Roy	Chemical Metering Pumps
Pulsafeeder	Chemical Feed Pumps, Metering Pump Controllers
SJE Rhombus	Custom Control Panels, Tanks Alert Alarms, Level Monitoring, Float Switches
Sta-Rite	Lift Stations, Sump, Effluent & Sewage Pumps, Grinder Pumps
Zoeller	Lift Stations, Grinder Pumps, Pump/Basin Packages, Specialty Pumps, Hazardous Environment Pumps

What to expect from Milby?

- △ Personalized Service
- △ Knowledgeable staff
- △ Training Classes
- △ Prompt Delivery
- △ Competitive pricing
- △ Equipment Recommendation
- △ Equipment Testing
- △ Technical Assistance
- △ Water Testing & Analysis
- △ Over 80 years of experience in the water industry

Contact us

For more information, call or email us today!

info@milbyco.com
www.MilbyCo.com

Headquarters: 1.800.796.7000
Colonial Heights: 1.866.645.2982
Frederick: 1.855.529.0841

Industries Served

Public Water Systems
Hospitality Industries
Laundry Facilities
Car/Truck Wash
Chemical & Food Processing
Agricultural Operations
Schools & Hospitals
Housing Developments
Manufacturing



MODY PUMPS, INC.

2166 Zeus Ct.

Bakersfield, CA 93308

Phone: 661/392-7600

FAX: 661/392-7601

Web Site: www.modypump.com

Products: AP, CP, DP, GP, IP, SH, TP, O (Submersible Pumps and Mixers)

Sales Contact: Barbara Taira, Inside Sales. 661/392-7600 FAX: 661/392-7601

barbara@modypump.com

Technical Contact: Paul Aguilar, Service and Operations Manager. 661/392-7600 FAX: 661/392-7601

paul@modypump.com

Mody Pumps®, Inc. is one of the fastest growing submersible pump manufacturers worldwide. We draw from almost half a century of experience in the submersible pump industry to deliver products that embody superior quality, reliability, peerless customer service and solid after-sales support. We serve the dewatering, municipal, industrial, marine, rental and waste management markets by offering a complete range of dewatering pumps and a full line of wastewater and sewage pumps.



MSP SERIES

FEATURES

- Dry Pit, Wet Pit & Portable installations
 - Discharge size: 3-12" / 75-300 mm
- Flow Range: 40-9,200 gpm / 152-34,825 lpm
- HP / kW Range: 4-180 HP / 3-93 kW - 60/50Hz
 - High Efficiency Motors
 - Class H (180 °C) Insulation
- "Fast Change" SC/SC Cartridge Mech. Seals
 - Adjustable Wear Ring System
- Vortex or Enclosed Impeller, on same Shaft/Volute
 - Latch-Bolts for Fast-Lock & Quick Release
 - Oil Tap Drain
- Optional: Self-Contained "Eco-Friendly" Cooling System

PUMPING SINCE 1957



**SERVICING THE DEWATERING,
MINING & WASTEWATER MARKETS
PUMPING SINCE 1957**

Phone: 661-392-7600 sales@moddypump.com

www.moddypump.com

Bakersfield, CA, USA Corporate HQ

MOTOR PROTECTION ELECTRONICS (MPE)

2464 Vulcan Road

Apopka, FL 32703

Phone: 407/299-3825

FAX: 407/294-9435

Web Site: www.mpeelectronics.com*Products:* AT, CP, LA, PM*Sales Contact:* John Evans, Presidentjohn_evans@mpeelectronics.com*Technical Contact:* Chris Parker, Engineeringchris_parker@mpeelectronics.com

Motor Protection Electronics is a leader in the design and manufacturing of Industrial Controls. Founded in 1983, our philosophy is to manufacture Controls and Controllers that are easy to use. We offer a full line of Industrial Controls for the Water and Wastewater industry, along with excellent customer service, technical support, and product availability.

Simple, Reliable, Durable, Rugged, Dependable

The Duplexer and the ISD Controllers operate from either Floats or the Level Probe. The Station Controllers SC1000 and SC2000 receive their level control input via a 4-20mA signal, floats or the Level Probe.

All MPE Controllers come SCADA-Ready with a RS232 Serial Port for MODBUS RTU control as a standard feature.

The ISD, SC1000 and SC2000 can also be ordered with an Ethernet Port for MODBUS TCP/IP control.

In late 2016, the SC2000 Controller will feature the DNP3 protocol over Ethernet.

**3 year
Warranty**

**Proudly Made
in the USA**

tel • 4 0 7 • 2 9 9 • 3 8 2 5

web • www.mpeelectronics.com

Simply The Best Resource

Simple, Reliable, Durable, Rugged, Dependable

Offering a full line of industrial controls for the water and wastewater industry.

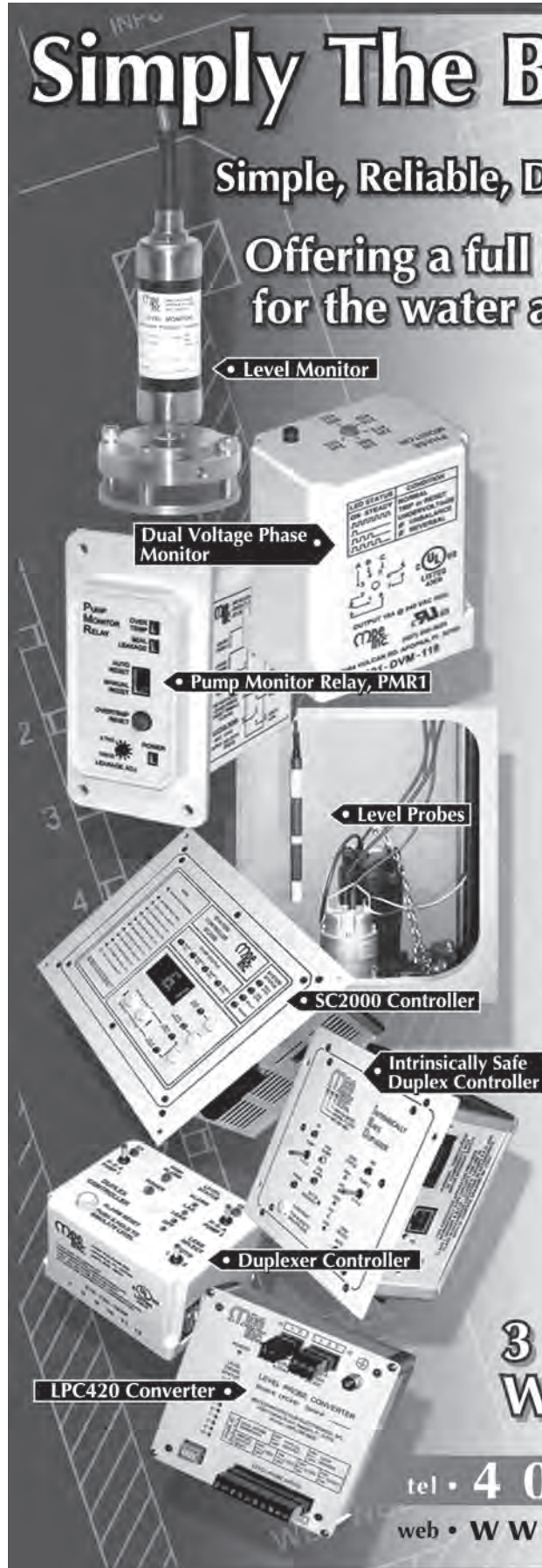

• Level Monitor

• Dual Voltage Phase Monitor

• Pump Monitor Relay, PMR1

• Level Probes

• SC2000 Controller

• Intrinsically Safe Duplex Controller

• Duplexer Controller

• LPC420 Converter

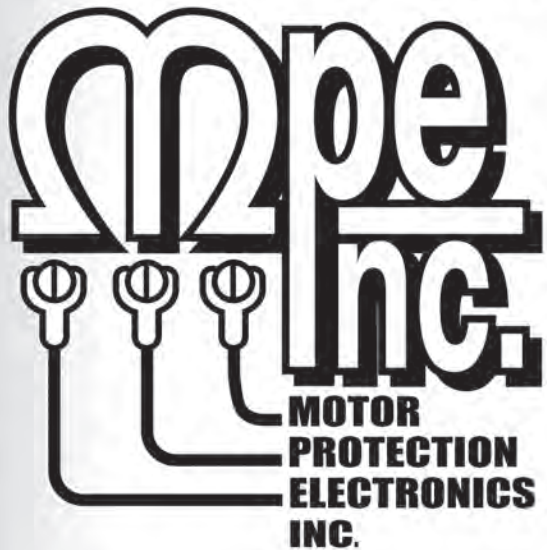

- In Business Since 1983
- No Minimum Purchase
- Same Day Shipping on most items
- Great Customer Service
- Great Technical Support
- Transient Tough Designs
- A Friendly Voice Answers the Phone!

**3 year
Warranty**



tel • 407 • 299 • 3825
web • www.mpelectronics.com

OHIO ELECTRIC CONTROL, INC.

2395 Rock Road
 Ashland, OH 44805
 Phone: 419/289-1553
 FAX: 419/289-5555
 Web Site: www.oecinc.net



Products: AT, CP, CT, LA, PC, PM, SS, VFD, OO
Sales Contact: Jennay Cacchio, Operations Managers. 419/289-1553
 jennay@oecinc.net
 Leslie Blankenship, Manufacturing Manager. leslie@oecinc.net
Technical Contact: Dave Baker, Engineering Supervisor. 419/289-1553
 dave@oecinc.net

Ohio Electrical Control is ready to serve your control panel needs with our state-of-the-art 20,000 square-foot manufacturing facility. We are proud to have a full metal fabrication shop on site to make any modifications or to engineer any part needed to fulfill your order. OEC is a UL, CUL, and CSA Certified shop. We can build control panels to the UL508A and UL698A standards. Ohio Electric Control has a strong reputation in the water treatment industry. We are forging new relationships with industrial customers and currently forming a division which focuses on OEM controls. Our engineering staff is always ready to quote custom panels to meet your control needs.



**OHIO ELECTRIC
 CONTROL, INC.**

Quality Products for the Electric Control Industry

**2395 Rock Road
 Ashland, Ohio 44805
 Phone: 419-289-1553
 Fax: 419-289-5555
 WWW.OECINC.NET**



MISSION STATEMENT

To make long lasting relationships with our customers by providing world-class service each and everyday. We pride ourselves in building a superior quality product, with timely delivery, and at a competitive price.

Timely Delivery

We pride ourselves on a quick turn around time of purchase to delivery.

Superior Quality Product

For over 35 years we have always chosen quality over quantity and in 2013 it isn't any different.

Valuing People

We strive to empower our employees to make decisions that enrich the experience for our customers.

Competitive Price

We continue to monitor our competition so that we still remain one of the best priced for the products we sell.

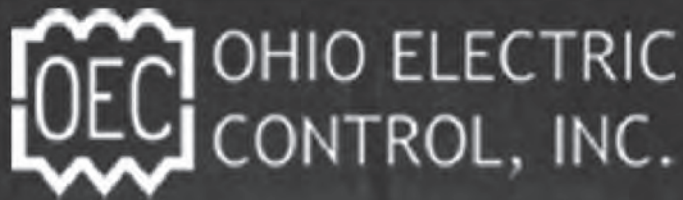

Ohio Electric Control, Inc.

Control Panels
On-Site Accessories
Float Switches
UL, CUL, and CSA Certified
Custom Controls and Design



Electric Control Panels

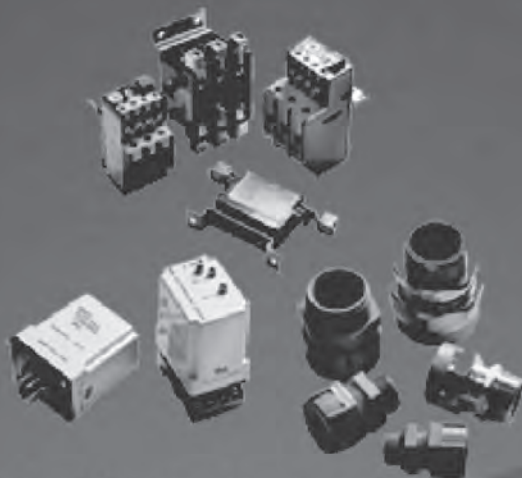

Quality Parts Provider



Accessory Provider

419-289-1553

Call Today for your FREE catalog
or download catalog FREE at
www.hecinc.net/catalog.pdf

PENTAIR

5500 Wayzata Blvd, Suite 600

Minneapolis, MN 55416-1261

Phone: 763/545-1730

FAX: 763/656-5400

Web Site: www.pentair.com

Products: AP, AC, BS, CP, DP, GP, IP, SH, TP, OP, CC, CT, EM, GR, LA, PC, PM, PB, SE, SS, VA, VFD, WW

Sales Director: Joe Jackson 913/748-4202. FAX: 913/748-4025

joe.jackson@pentair.com

Engineering Manager: Barry Jongsma 913/748-4153. FAX: 913/371-6969

barry.jongsma@pentair.com

Product Marketing Manager: Nicole Osborne 419/281-9225. FAX: 888/207-0597.

nicole.osborne@pentair.com

Pentair's Fairbanks Nijhuis line offers world class custom engineered solutions for the global pumping industry. Offering complete system solutions, Fairbanks Nijhuis globally serves the infrastructure, industrial, irrigation, oil & gas and fire protection markets.

Pentair's Hydromatic line represents one of the most diversified lines of submersible sump, sewage, effluent, grinder, solids handling and self-primer pumps for the municipal, industrial, commercial, residential, domestic and international markets.



HYDROMATIC®

Hydromatic provides engineered solutions for the entire wastewater sewage spectrum including traditional gravity, alternative sewer, decentralized solutions and on-site treatment.





The First Premium Efficient Oil-Filled Motor in a Submersible Pump

HYDROMATIC® HPE SERIES

- Oil-Filled Motor for the Ultimate in Reliability, Heat Dissipation, and Continuous Lubrication
- Upgraded Serviceability and Maintenance-Free Operation
- Engineered with Innovative Features for Today's Challenging Wastewater Environment.

www.hydromatic.com



FAIRBANKS NIJHUIS®

ENGINEERED SOLUTIONS

Providing a wide range of pumps and pumping solutions for global infrastructure and industrial market applications.

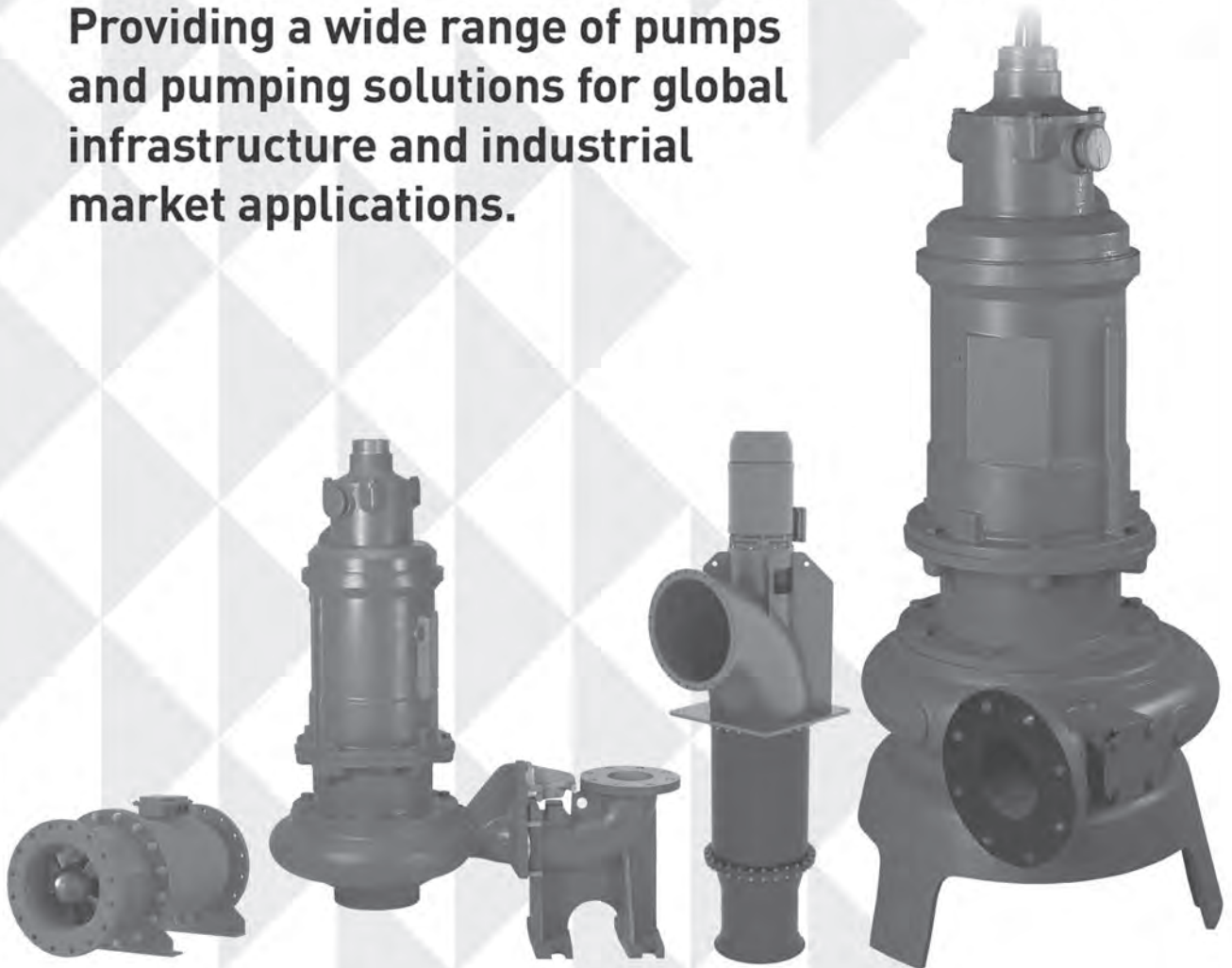

PUMPS & SYSTEMS MAGAZINE

1900 28th Avenue South
Birmingham, AL 35209

Phone: 205/212-9402

FAX: 205/314-8272

Web Site: www.pumpsandsystems.com

PUMPS&SYSTEMS
The Leading Magazine for Pump Users Worldwide

Products: magazine, website, e-newsletters, webinars, eblasts

Sales Contact: Darrell Moody, Account Executive
dmoody@pump-zone.com

Editorial Contact: Alecia Archibald, Senior Editor
aarchibald@cahabamedia.com

Pumps & Systems is the voice of the global pump and rotating equipment industry. For 22 years, it has served as the leading magazine for pump users worldwide, delivering relevant industry news coverage and powerful technical information to more than 40,000 BPA-qualified managers, engineers, operators and maintenance professionals. *Pumps & Systems* and its sister publication, *Upstream Pumping*, is available for free to qualified subscribers in print and digital formats. *Pumps & Systems* is supported digitally by the No. 1 pump industry website, www.pumpsandsystems.com. The publication also offers newsletters with timely information: *Pump Users Digest* and *Products for Pump Users*.

More Than a Magazine

Choose *Pumps & Systems* Multimedia
to extend your reach

Pumps & Systems is the pumps and rotating equipment magazine that end-users have come to trust. In addition to our respected publication, *Pumps & Systems* offers a wide variety of digital products to fill any advertising or promotional need:

- Website: pumpsandsystems.com
- E-newsletters
- Customized e-blasts
- Fully facilitated webinars
- White paper marketing
- Online content marketing



To find out how the experts at *Pumps & Systems* can help your company grow, contact your sales executive, or Derrell Moody at dmoody@pump-zone.com, +1 205-345-0784

PUMPS&SYSTEMS
The Leading Magazine for Pump Users Worldwide

FOLLOW THE LEADER

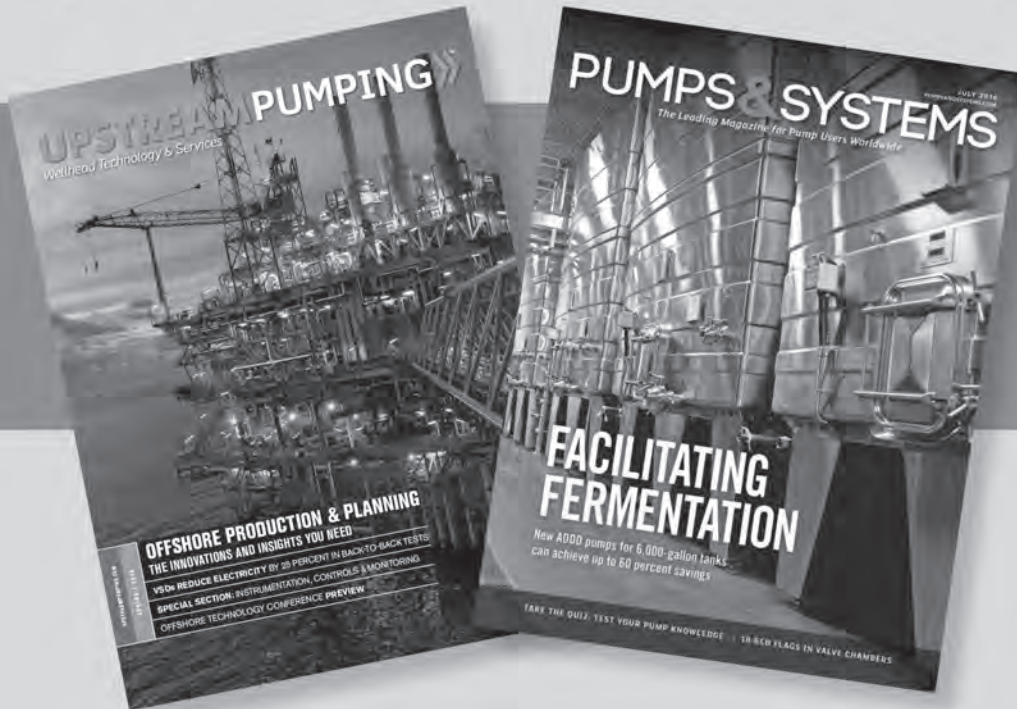

COMPREHENSIVE COVERAGE
RELEVANT CONTENT
CASE STUDIES
WORLDWIDE NEWS
TECHNICAL ARTICLES

To subscribe to our print or digital editions and to sign up for our e-newsletters, visit our websites and click on **SUBSCRIBE**.

PUMPSANDSYSTEMS.COM

UPSTREAMPUMPING.COM

ROCKWELL AUTOMATION, INC.

1201 South Second Street
Milwaukee, Wisconsin 53204

Phone: 414-382-2000

Web Site: www.rockwellautomation.com/industries/water



**Rockwell
Automation**

*Products:**Architecture & Software*

This segment contains key elements of the Rockwell Automation control and information platforms, software applications and automation components.

Control Products & Solutions

This segment consists of motor control products, solutions and services.

Sales Contact: Christa Bankay, Commercial Program Manager. 519/244-5320.

cdbankay@ra.rockwell.com

Technical Contact: Kelvin Hurdle, Manager, Business Development.

602/697-7372. kjhurdle@ra.rockwell.com

Rockwell Automation, Inc., the world's largest company dedicated to industrial automation and information solutions, helps make its customers more productive and the world more sustainable.

The PlantPAX™ Process Automation System leverages the core Integrated Architecture™ technologies and custom solutions for plant-wide control. Combined with intelligent motor control, PlantPAX can help you to reduce downtime, increase productivity, reduce energy use and improve safety. Predict and prevent maintenance issues, boost performance and protect your assets with process automation control from Rockwell Automation.

**Pump control – meet intelligence.**

Improve your pump operations with Intelligent Motor Control solutions from Rockwell Automation. With easy access to control and diagnostics, you can make better decisions to help achieve optimum pump performance.



Learn more at:

www.rockwellautomation.com/solutions/intelligentcontrol

**Rockwell
Automation**

Allen-Bradley • Rockwell Software

Copyright © 2014 Rockwell Automation, Inc. All Rights Reserved. CENTERLINE® and PowerLine™ are registered trademarks of Rockwell Automation, Inc.

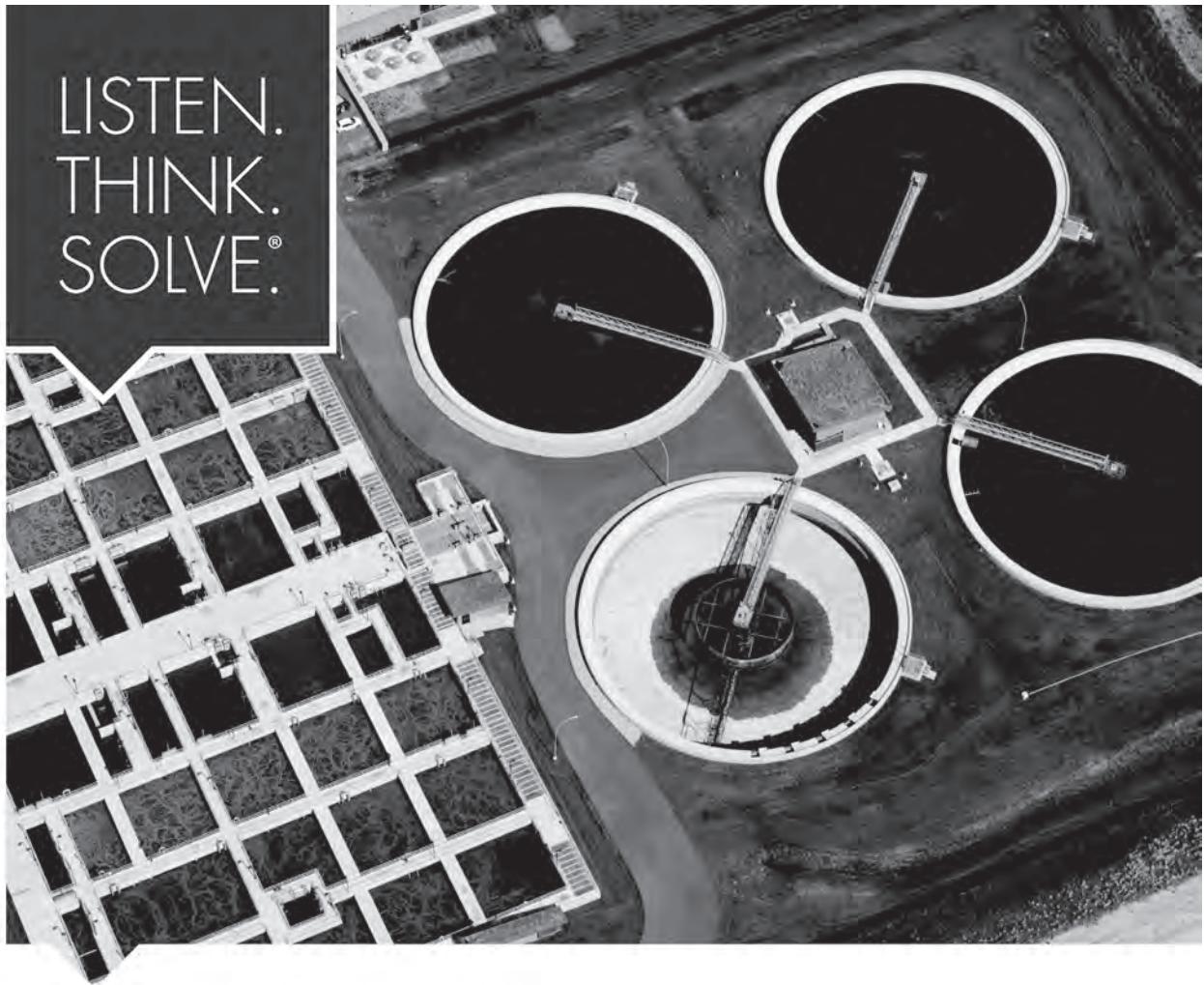

Aging infrastructure?
Stringent government regulations?
 Solve both with the PlantPAX™ process automation system.

This flexible, scalable plant-wide control solution delivers the intelligence to meet government regulations AND optimize the use of resources, manpower and equipment. Its open technology, combined with our industry experience, enable the creation of an ideal phased migration strategy. Spend less time managing operations and more time driving productivity.

Find out more at:
www.rockwellautomation.com/solutions/process

Copyright © 2014 Rockwell Automation, Inc. All Rights Reserved. PlantPAX™ is a trademark of Rockwell Automation, Inc.

**Rockwell
Automation**

 **Allen-Bradley • Rockwell Software**

SCHNEIDER ELECTRIC (SQARE D BY SCHNEIDER ELECTRIC)

8001 Knightdale Boulevard

Knightdale, NC 27545

Web Site: www.schneider-electric.com

Products: CO, CT, PC, PM, VFD, OO (soft starters, motor starters, circuit breakers, disconnects, programmable logic controllers, sensors and other electrical and electronic devices used in conjunction with the submersible pump industry)

Sales Contact: Jack Creamer, Segment Manager–Pumping Equipment.
919/217-6464 or jack.creamer@schneider-electric.com

Technical Contacts: Siva Kanesvaran, Application Development Engineer.
919/266-8605 or siva.kanesvaran@schneider-electric.com

Schneider Electric: Your partner for intelligent, energy-saving pumping applications

From the most basic application to the most complex project, Schneider Electric is committed to your success in the pumping marketplace. To meet the challenges in today's complex market, you need more than an equipment supplier — you need a solutions provider.

Schneider Electric is an innovative partner committed to helping you solve your most complex challenges while working with you to adopt the latest technology for your needs. We provide a broad range of cutting edge Control, Automation and power solutions that exceed expectations in the pumping industry. With 150 years of experience, we are dedicated to helping your company find a strategic edge in the market, whether you're focused on water/wastewater, commercial and industrial building, industry, irrigation, or residential. We have the right solution for your application requirements and the expertise to make it work! For more information, visit www.schneider-electric.us/pumping.

For more information, contact us at 888-778-2733 or visit www.schneider-electric.us/go/pump.





How can you reduce total cost of ownership and optimize pump performance?

Altivar Drives: Advanced energy management and performance in motor control

For more than 30 years, Schneider Electric has supplied AC drives to energy-intensive industries worldwide. Today, the family of Altivar Drives offers the most advanced and user-friendly variable-speed AC Drives and Drive Systems offering on the market.

Featuring proprietary motor control algorithms to achieve optimal motor performance and complete scalability to match your application speed, size, and protection requirements, the complete line of Altivar products and solutions delivers the flexibility and performance to:

- Optimize a broad range of utility and industrial applications including pumps, fans, compressors, material handling, hoisting, packaging, and material working.
- Reduce energy costs by using proprietary energy saving technologies available only from Schneider Electric.
- Improve uptime by simplifying installation, commissioning, and maintenance by providing advanced diagnostics, industry-leading voltage ride-through capability, and seismic-qualified products and solutions.

Altivar Process drives have been specifically designed for industrial pumping processes, including:

- | | |
|--------------------|---------------------|
| • Irrigation | • Mining & Minerals |
| • Industrial | • Buildings |
| • Water/Wastewater | • Residential |
| • Oil & Gas | • And more! |



For more information, visit www.altivardrives.com.

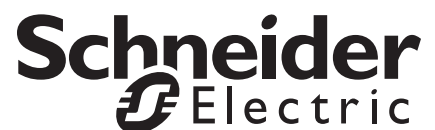

SJE-RHOMBUS

22650 County Highway 6, P.O. Box 1708

Detroit Lakes, MN 56502

Phone: 888/342-5753 or 218/847-1317

Web Site: www.sjrhombus.com

Products: AT, CP, CT, LA, PC, PM, SS, VFD

Sales & Technical Assistance: Loran Knudsvig, Sales Director – Standard Products.

Cell: 218/850-0961. Office: 218-847-1317, Ext. 3404.

Loran.Knudsvig@sjrhombus.com

SJE-Rhombus® is a leading control solutions provider, combining 40 years of expertise in pump controls with the latest technology to deliver energy efficient, cost-effective products for a wide variety of residential, commercial, municipal, industrial and agricultural applications. No matter the application, SJE-Rhombus has a control solution to fit your needs, whether it's a simple float switch or septic alarm system to control panels using embedded circuit board technology for advanced programming and monitoring of your system. And if we don't have it in our standard catalog, we can design and build a custom solution to meet your exact specifications. With corporate headquarters located in Detroit Lakes, Minnesota, SJE-Rhombus does business globally from seven locations across the United States and Asia. SJE-Rhombus is a 100% employee-owned, privately held company. To learn more, **visit www.sjrhombus.com**.

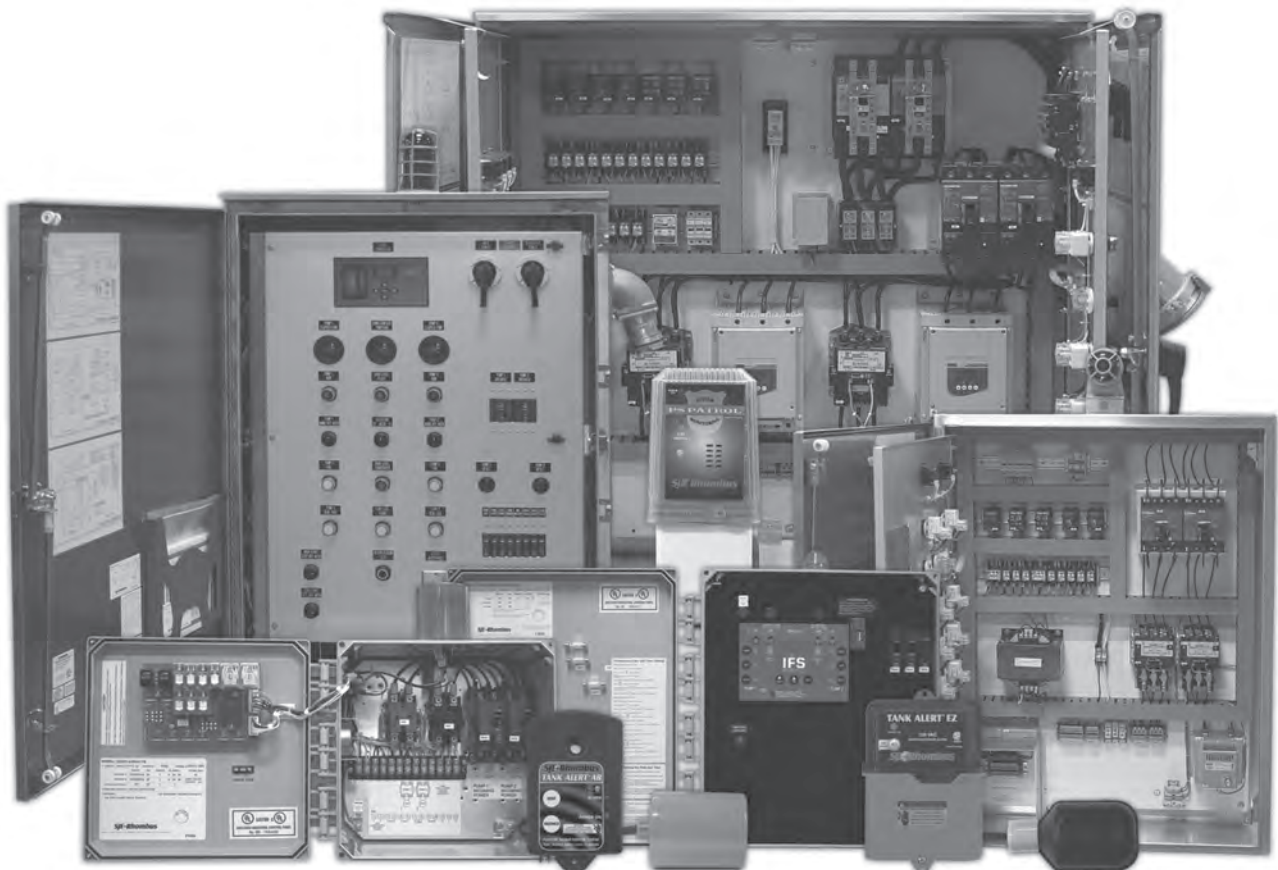

Smart Solutions

Custom Designed and Manufactured for Your Application

Whether you need high volume, repetitive control panels or a one-off custom control solution, SJE-Rhombus® is your preferred partner. With 40 years of experience working with original equipment manufacturers (OEMs), we provide high quality, cost-effective custom control solutions for a variety of applications:

- Water and Wastewater Controls
- Agriculture, Irrigation and Dewatering Controls
- Variable Frequency Drives (VFDs) for Pump Control
- Communications, Data Logging and Event Monitoring
- Embedded Microprocessor Controller Design
- Programmable Logic Control (PLC) Programming
- Man-Machine Interface (MMI) Programming
- Military and institutional Controls
- Smart Grid Enabled Controls
- Temperature Controls
- Sampling Controls
- Process Controls
- Motion Controls
- Pattern Controls



SJE
Rhombus®



Toll Free: 1-888-342-5753
www.sjehombus.com

SULZER PUMP SOLUTIONS (US), Inc.

140 Pond View Drive

Meriden, CT 06450

Phone: 203/238-2700

FAX: 203-238-0738

Web Site: www.sulzer.com**SULZER***Products:* AP, CP, DP, GP, IP, SH, AC, BS, CP, CT, GR, LA, PC, PM, PB, SE, SS*Sales Contact:* John Everhart, Regional Head Sales America
john.everhart@sulzer.com

Sulzer offers the most advanced equipment for water production, transportation, wastewater collection and treatment for municipalities and industries. These products include submersible pumps, mixers, flow boosters, aeration systems, turbocompressors, and easy-to-use systems for monitoring and control. We have more than 100 years of application experience and manufacturing customer-oriented solutions using leading technology. The ABS XFP range of submersible wastewater pumps incorporated the first premium-efficiency IE3 motor designed and tested with IEC60034-30 together with optimized hydraulics - yielding the best total efficiency available on the market today.



Uncompromising Blockage Protection

SULZER

As the rags and solids in wastewater increase, you need innovation that keeps pumping stations problem-free. The submersible sewage pump type ABS XFP from Sulzer, with its versatile range of Contrablock Plus impellers, is insurance against downtime that's easy to acquire.

The impellers' superior rag handling and minimum free solids passage of 75 mm mean you spend far less time on troublesome pumping stations. Switching from an existing pump is easy, and you save energy immediately with the XFP's premium-efficiency IE3 submersible motor - which Sulzer pioneered and provides as standard.

For more innovation in wastewater collection, visit www.sulzer.com

Reliability and lower cost of operation in water and wastewater applications

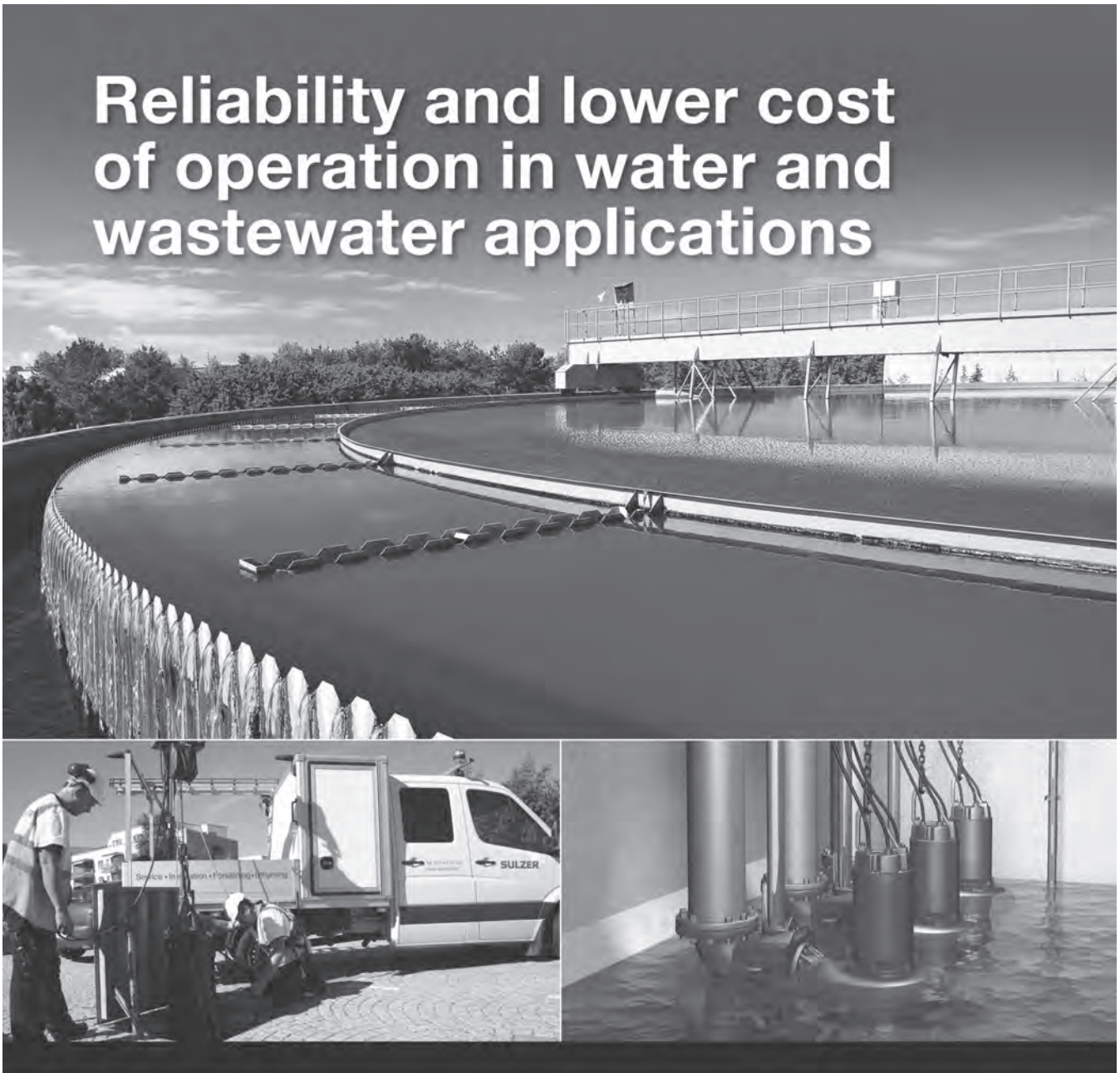

SULZER

Sulzer provides a full range of pumps, mixers, aeration systems and controllers for the main applications in water and industrial – and municipal wastewater treatment.

Our innovative solutions ensure higher reliability and energy savings of up to 25-30% – which makes all the difference in reducing the cost of operations of your plant.

With a wide service network, Sulzer also offers a fast and efficient response to the specific needs of each customer.

Contact us and find out how Sulzer solutions can revolutionize your processes.

www.sulzer.com

TOPP INDUSTRIES INC.

P. O. Box 420, Highway 25 North
Rochester, IN 46975

Phone: 800/ 354-4534

FAX: 574/223-6106

Web Site: www.toppindustries.com



Products: AC, BS, GR, LA, PS, PB, SE, WW, OO

(Structural Foam Basins and Prefabricated Lift Stations)

Sales Contacts: Ed Kelso 574/224-8653. ekelso@toppindustries.com

Timothy Merkel, Outside Sales Manager. 419/908-7612.

tmerkel@toppindustries.com

Technical Contact: Judy Terry, Engineered Sales and Customer Service.

574/224-8653. jterry@toppindustries.com

TOPP Industries, Inc. is the leading manufacturer in fiberglass pre-fabricated lift stations. TOPP has fiberglass tanks from 18" thru 120" diameter. Package lift stations are available with attached and unattached valve boxes, that allows the valves, controls and service personnel to be isolated from the wet well. TOPP also has specialists to assist with your specifications and drawings - contact one of our customer service representatives for more information. In addition to lift stations, TOPP also carries a complete line of polyethylene and structural foam basins for your individual needs. To learn more, visit www.toppindustries.com.



A proven leader in sewage, sump and wastewater markets, TOPP offers high-quality environmentally responsible products, including fiberglass, polyethylene and structural foam basins, tanks, basin and tank covers, lift stations, septic tank risers, extensions and accessories.



Rochester, IN 46975 • (800) 354-4534 • www.toppindustries.com



Engineered Solutions You Can Trust

Fiberglass pre-fabricated lift stations, rail systems and more.



Building for the Future

Providing the best fiberglass, polyethylene and structural foam
sewage, sump and wastewater basins.

Made proudly in America.

www.toppindustries.com
(800) 354-4534

VAL-MATIC VALVE & MFG. CORP.

905 Riverside Drive
Elmhurst, IL 60126

Phone: 630/941-7600

FAX: 630/941-8042

Web Site: www.valmatic.com



Products: VA

Sales Contact: Diane Meyer, Marketing Manager.

630/993-4022 Fax: 630/993-4087. dmm@valmatic.com

Technical Contact: Ed Gardner, Account Manager.

630/993-4018. edg@valmatic.com

Val-Matic is a leading manufacturer of Air Valves, Check Valves and Quarter Turn Shut-Off Valves for water/wastewater, power, industrial, fire protection and HVAC applications. Val-Matic offers six types of check valves including: **Surgebuster®**, **Tilted Disc®**, **Dual Disc®**, **Swing-Flex®**, **Swing Check** and **Silent Check Valves** to meet various applications. The line of shut-off valves consists of the **Ener-G® AWWA Rubber Seated Ball Valve**, the **American-BFV® Butterfly Valve** and the **Cam-Centric® Plug Valve**. Val-Matic is the first **Air Valve** manufacturer to have a complete line of air valves certified to NSF/ANSI 61 Standard for Drinking Water System Components. All Val-Matic products are NSF/ANSI 372 Certified Lead-Free by the Water Quality Association (WQA). For more information, visit our website at www.valmatic.com.

Quality Valves for Quality Pumps

The Perfect Solution for Your Pumping Applications

NSF/ANSI 372 Certified Lead-Free



Clean Water
Air Valves



Surgebuster®
Check Valves



Wastewater
Air Valves



Swing-Flex®
Check Valves

VAL-MATIC®

Manufacturing Quality Valves since 1966

ISO 9001 Certified

www.valmatic.com • 630-941-7600 phone

Reliable. Energy Efficient. Quarter-Turn Valves



American-BFV® Butterfly Valves

- Available in sizes 3"-144"
- Full compliance with AWWA C504, C516, NSF/ANSI 61 and 372
- Continuous uninterrupted seating
- Multiple actuation options available

Ener•G® Ball Valves

- Available in sizes 4"- 48"
- Full compliance with AWWA C507, NSF/ANSI 61 and 372
- 100% full flow area equal to pipe size
- Preferred for surge control & energy savings

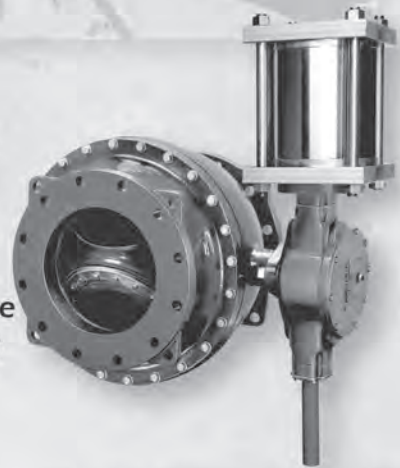

Cam-Centric® Plug Valves

- Available in sizes 1/2"- 60"
- Full compliance with AWWA C517 and NSF/ANSI 372
- Totally encapsulated molded plug
- 3-Way and 4-Way taper style available

VALMATIC®

(630) 941-7600
www.valmatic.com



WEIL PUMP COMPANY, INC.

W 57 N 14363 Doerr Way, P.O. Box 887
Cedarburg, WI 53012

Phone: 262/377-1399

FAX: 262/377-0515

Web Site: www.weilpump.com



Products: AP, CP, DP, GP, IP, SH, AC, AT, BS,
CC, CP, CT, EM, GR, LA, PM, SE, SS, VA, VFD, WW

Sales Contact: Tim Bade, tbade@weilpump.com

Technical Contact: Jeff Plaster,
jplaster@weilpump.com

Weil Pump designs and manufactures centrifugal pumps for building, municipal, and industrial applications. Weil Pump specializes in pumps for wastewater handling, condensation return, and hot and cold water circulation. Weil builds Submersible, Vertical and Dry Well type pumps. Sewage, Sump, Grinder, and Effluent models are available with standard or U/L XP motors — all air filled. Weil offers Vertical and Submersible models in stainless steel for corrosive applications. Removal Systems, Duplex Wastewater Valves, Control Panels, and Wet Well Covers provide a complete package. Visit our website at www.weilpump.com for additional information.

Weil has complete wastewater systems

Weil produces a complete line of wastewater pumps and accessory items. Specify the product style that best suits the application.

Vertical – NEMA motors

Submersible

Single seal or double seal

60 or 50 Hz

UL explosion proof motors

Dry Well – Submersible or NEMA motors

Grinder/Slicer – Submersible or NEMA motors

Stainless Steel – Vertical or Submersible

Accessories

Removal Systems

Valving

Control Panels – simplex, duplex, triplex

Wet Well Covers

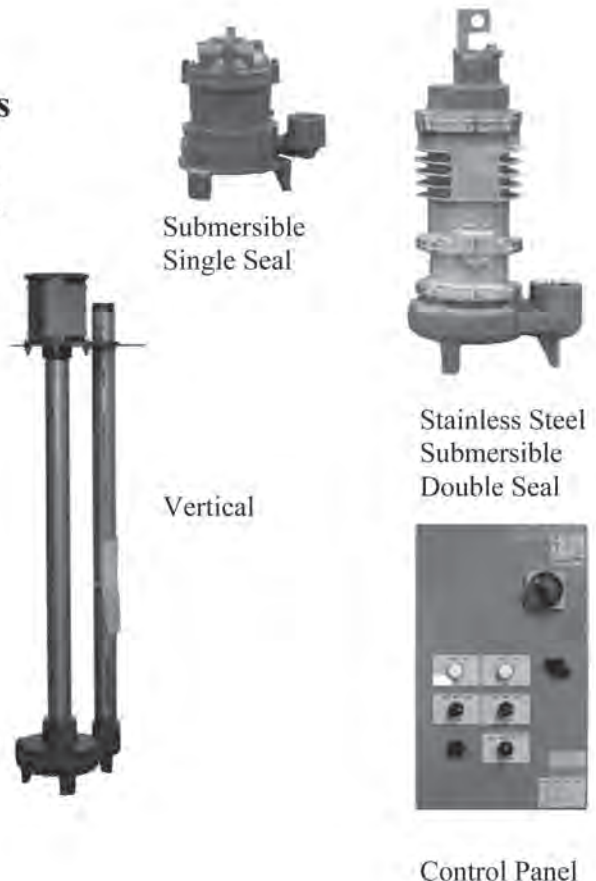

Submersible
Single Seal

Stainless Steel
Submersible
Double Seal

Vertical

Control Panel

WEIL

Pump Co Inc™

Simply the best.

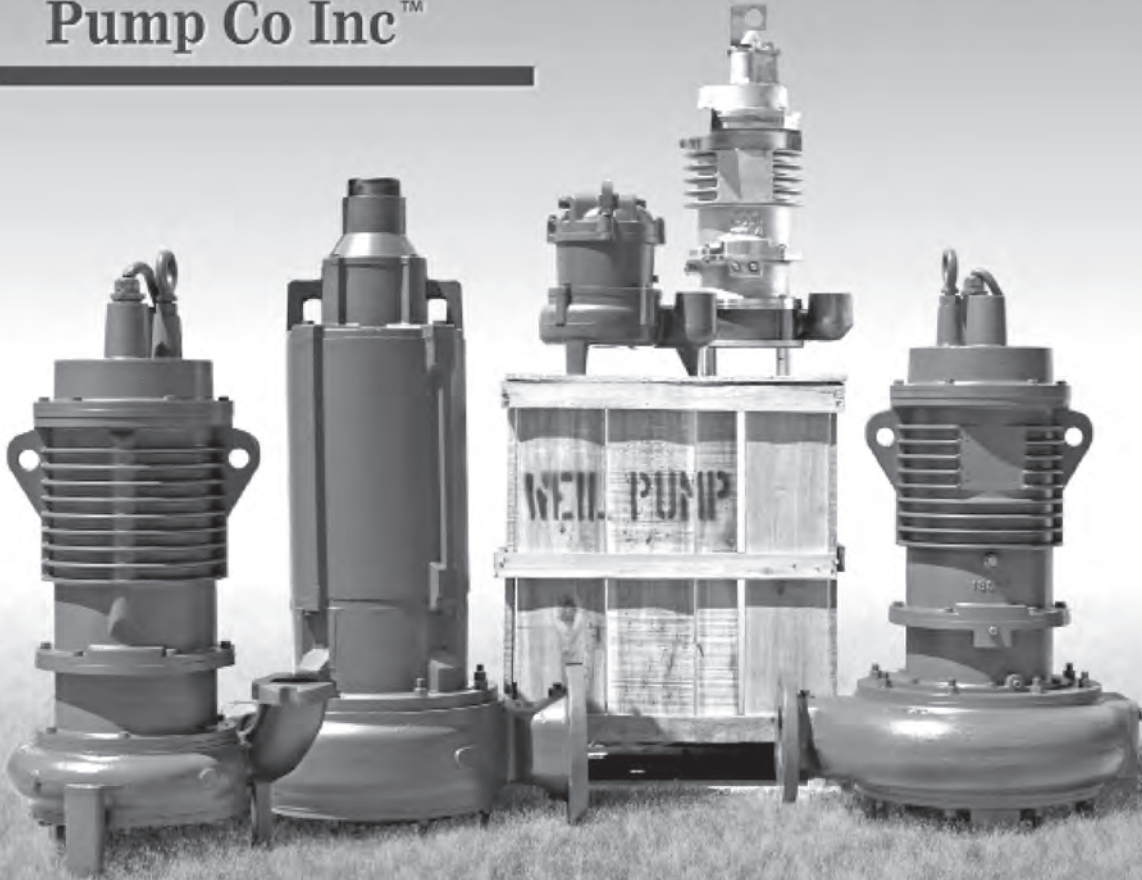

Wastewater

• Pumps • Accessories • Controls

MADE IN THE
USA

ZOELLER ENGINEERED PRODUCTS

3649 Cane Run Road

Louisville, KY 40211-1961

Phone: 800/928-7867

FAX: 502/774-3624

Web Site: www.zoeller.com**ENGINEERED PRODUCTS***Zoeller Family of Water Solutions™*

Products: CP, DP, GP, SH, AC, AT, BS, CT, GR, LA, PB, VA, WW

Sales Contact: Steve Doolittle, Product Line Manager.

Ext. 8215. steved@zoeller.com

Technical Contacts: Andrew Ulliman, Product Engineer.

Ext. 8130. andrewu@zoeller.com

For over 75 years, craftsmen from Zoeller company have been manufacturing quality, American made products. From their small residential submersible pumps to heavy duty industrial pump packages, you can put your trust and confidence behind Zoeller's quick deliveries, competitive prices, and toll-free technical support.

Grinder and Solids Handling Pumps



Explosion Proof also available



ENGINEERED PRODUCTS

Zoeller Family of Water Solutions™

Submersible Solids Handling Pumps, Grinder Pumps & Packaged Systems

Applications for pumping liquids containing solids:

- Engineered Lift Stations
- Storm Water Removal
- Wastewater Transfer
- Pressure Sewer
Systems
- Industrial Wastewater
- Class I, Division 1
Hazardous Locations

1/2 - 100 HP

Your Peace of Mind is Our Top Priority®

www.zoellerengprod.com

3649 Cane Run Road • Louisville, KY 40211 • 502-778-2731 • 1-800-928-7867 • fax 502-774-3624



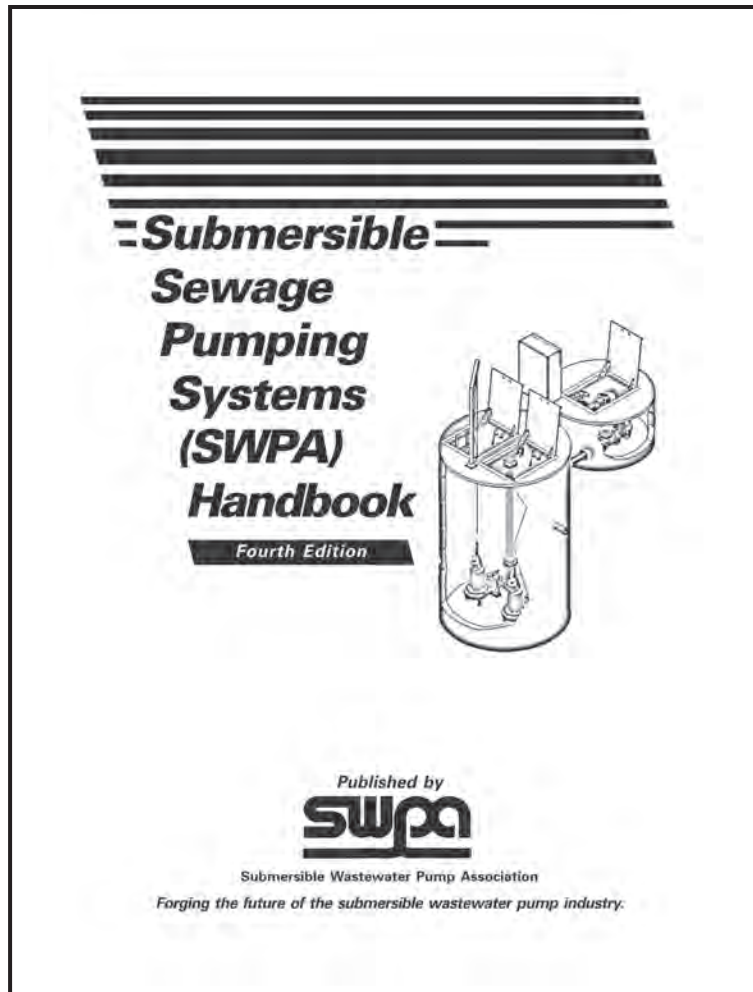

ORDER YOUR COPY TODAY!

**THE 4TH EDITION OF THE
SUBMERSIBLE SEWAGE PUMPING SYSTEMS
(SWPA) HANDBOOK.**

**PLEASE CONTACT SWPA
HEADQUARTERS AT 847.681.1868
OR CLICK ON THE LINK
“SWPA HANDBOOK – 4TH EDITION” AT
WWW.SWPA.ORG**

Rely on This Symbol



**Submersible Wastewater Pump Association
350 North LaSalle Street, 9th Floor ♦ Chicago, IL 60654
Phone: 847.681.1868 ♦ FAX: 312.475.9022
E-Mail: swpaexdir@sbcglobal.net**

For more information about the Association and the industry it serves,
Visit our Web Site at www.SWPA.ORG